

PROFIBUS DP Gateway

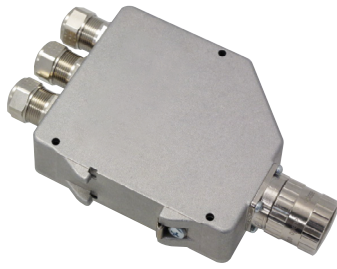

PROFIBUS DP Gateway for EnDat encoders

- Functionality according to PROFIBUS DPV0, DPV1 and DPV2
- Integrated T-coupling and bus termination
- Compact and robust design



Electrical specification

Power supply	9-36 Vdc
Polarity protected	Yes
Current consumption, max without EnDat encoder	90 mA @ 24 Vdc
Current consumption, max	200 mA @ 24 Vdc
Output interface	PROFIBUS DPV0, class 1 and 2 / PROFIBUS DPV1, DPV2, class 3 and 4
Supported profiles	3.062 (DPV0) or 3.162 (DPV2)
Addressing	Decimal by coding switch, 0...126
Baud rate	9,6 kbit/s - 12 Mbit/s
Cable length	400 m @ 1,5 Mbit/s
Supported encoders	≤ 31 bit singleturn rotary encoder, ≤ 37 bit multiturn rotary encoder
Encoder interface	EnDat
Power supply	5 Vdc ±5%
Max output current to EnDat encoder	400 mA
Cable length	Max 40 m

Mechanical specification

Housing	Aluminium
Weight	Approx. 400 g
Vibration (10-2000 Hz)	< 100 m/s ² according to IEC 60068-2-6
Protection class	IP 65 according to IEC 60529
Temperature, operating	-40 °C .. +80 °C
Temperature, storage	-40 °C .. +80 °C
LED indication	Module and Bus
Connection, PROFIBUS	Cable glands or M12 connectors
Connection, EnDat	17 pin M23 connector ⁽¹⁾
Mechanical mounting	DIN-rail or screw

⁽¹⁾ 8 pin M12 connector available on request

Accessories

GSD file DPV0	Downloadable at www.leinelinde.com
GSD file DPV2	Downloadable at www.leinelinde.com
Mounting kit filler plug M16	Part no. 721908-01
Cable to encoder 17p M23, 2 m	Part no. 00201045
Cable to encoder 17p M23, 3 m	Part no. 00201057
Cable to encoder 17p M23, 20 m	Part no. 00201056
Cable to encoder 17p M23, free length	Part no. 01209050

PROFIBUS DP Gateway

Dimensions

CRG PROFIBUS cable gland x 3, M23

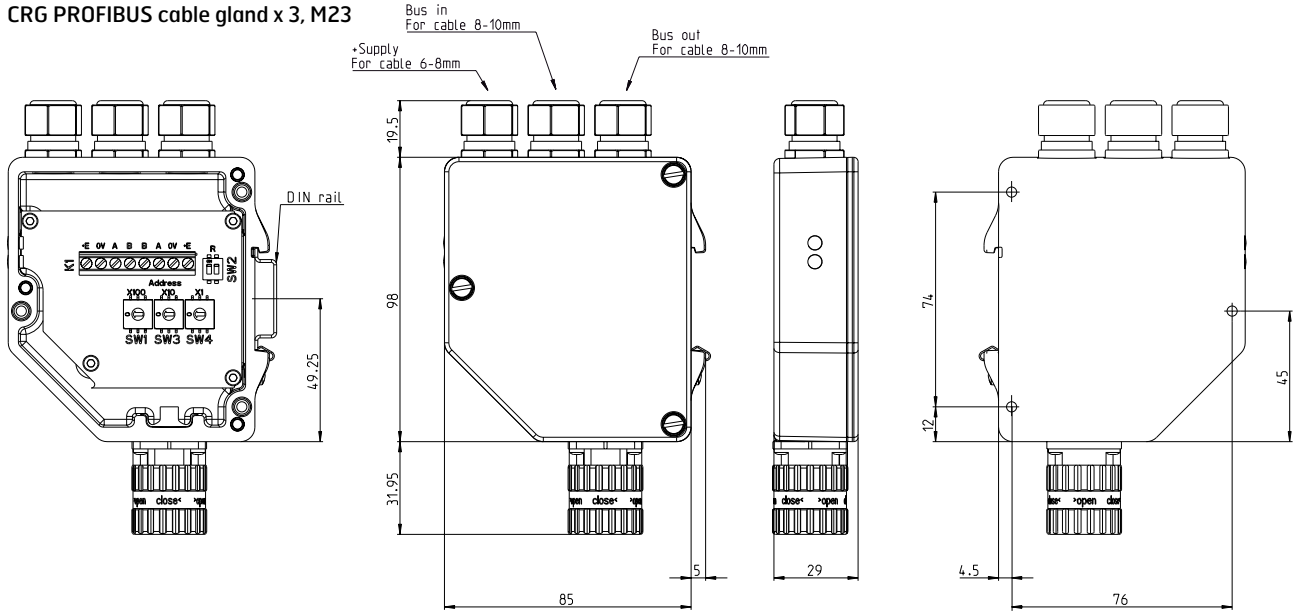

CRG PROFIBUS M12 x 3, M23

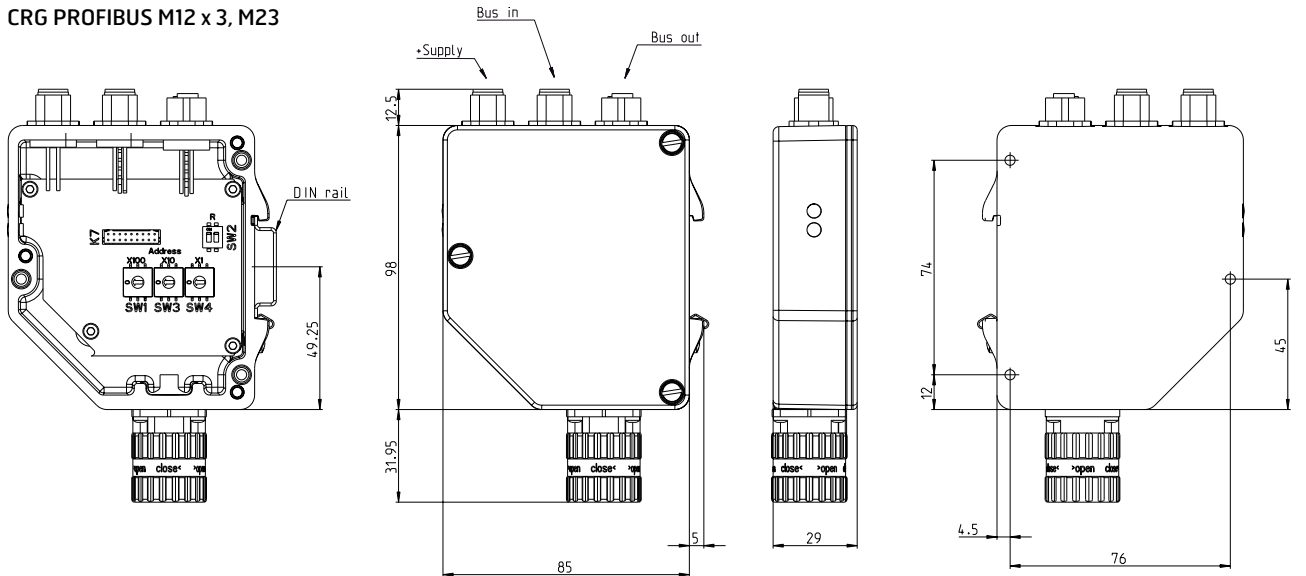

PROFIBUS DP Gateway

Connection



EnDat

17 pin M23

Function	Pin
Sensor + E Volt	1
Sensor 0 Volt	4
+ E Volt	7
0 Volt	10
Clock	8
Clock\	9
Data	14
Data\	17



PROFIBUS

Terminal, cable gland

Function	Marking
+ E Volt ⁽⁴⁾	+E
0 Volt ⁽³⁾	0V
A ⁽¹⁾ Bus in	A
B ⁽²⁾ Bus in	B
B ⁽²⁾ Bus out	B
A ⁽¹⁾ Bus out	A
0 Volt ⁽³⁾	0V
+ E Volt ⁽⁴⁾	+E
VP	
DGND	
Chassi	

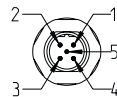

5 pin M12 male B-coded

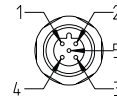

5 pin M12 female B-coded

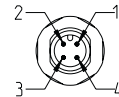

4 pin M12 male A-coded

Function	Marking	Pin	Pin	Pin
+ E Volt ⁽⁴⁾	+E	NA	NA	1
0 Volt ⁽³⁾	0V	NA	NA	3
A ⁽¹⁾ Bus in	A	2	NA	NA
B ⁽²⁾ Bus in	B	4	NA	NA
B ⁽²⁾ Bus out	B	NA	4	NA
A ⁽¹⁾ Bus out	A	NA	2	NA
0 Volt ⁽³⁾	0V	NA	NA	NA
+ E Volt ⁽⁴⁾	+E	NA	NA	NA
VP		NA	1	NA
DGND		NA	3	NA
Chassi		5	5	NA

⁽¹⁾ A terminals are internally connected to each other
⁽²⁾ B terminals are internally connected to each other
⁽³⁾ 0 V terminals are internally connected to each other
⁽⁴⁾ + E terminals are internally connected to each other
 NA = Not Available

PROFIBUS DP Gateway

PROFIBUS-DP Gateway

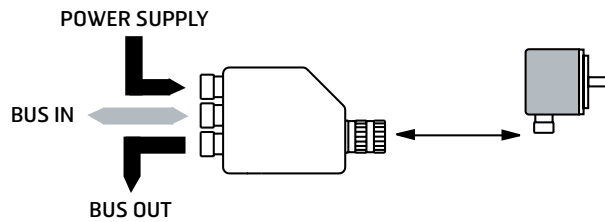

Advantages of the gateway concept

1. The gateway allows the use of small and robust encoders.
2. Cost effective exchange of encoder (no need to change the gateway).
3. Reduction of bus-cabling (only one cable between gateway and encoder is needed).
4. Flexible choice of encoders as the same gateway can be used with different encoders.
5. Advanced diagnostics integrated in the basic encoders.
6. Allows operation of encoder in high temperature and harsh environmental conditions.

Ordering information

PROFIBUS Gateway	Part no.
CRG PROFIBUS cable gland x 3, M23 connector	678695-01 ⁽¹⁾
CRG PROFIBUS M12 x 3, M23 connector	680190-01 ⁽²⁾

⁽¹⁾ 678695-01 is compatible with old part number 01300210

⁽²⁾ 680190-01 is compatible with old part number 01300250