

ifm electronic

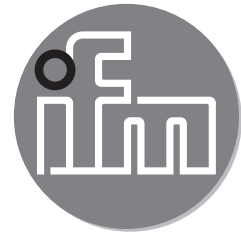

Operating instructions
Electronic level sensor

efector160[®]

LR3000

UK

05/2011

704913/00

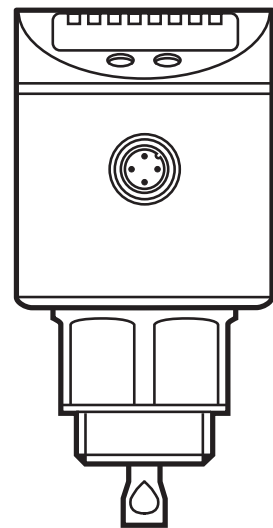

Contents

1	Preliminary note.....	4
1.1	Symbols used	4
2	Safety instructions	4
3	Items supplied.....	5
4	Functions and features	6
4.1	Operation with single probe.....	6
4.2	Operation with coaxial probe	6
4.3	Applications	7
5	Function.....	8
5.1	Measuring principle	8
5.2	Features of the unit.....	8
6	Installation.....	12
6.1	Installation location / environment	12
6.1.1	Unit with single probe	12
6.1.2	Unit with coaxial probe	15
6.2	Installation of the probe	15
6.2.1	Installation of the rod	15
6.2.2	Installation of the coaxial pipe	16
6.3	Shortening of the probe	16
6.3.1	Shortening of the rod	16
6.3.2	Shortening of the coaxial pipe	17
6.4	Installation of the unit with single probe.....	17
6.4.1	Installation in metal tanks	17
6.4.2	Installation in plastic tanks.....	19
6.4.3	Installation using a flange plate	19
6.5	Installation of the unit with coaxial probe in the tank	20
7	Electrical connection.....	20
8	Operating and display elements	22
9	Menu.....	23
9.1	Menu structure.....	23
9.2	Explanation of the menu	24

10	Parameter setting	25
10.1	General parameter setting.....	25
10.2	Basic settings (unit on delivery).....	27
10.2.1	Entering the probe length	27
10.2.2	Setting to the medium.....	27
10.2.3	Entering the type of probe used	27
10.3	Configuration of the display	28
10.4	Offset setting.....	28
10.5	Setting of output signals	28
10.5.1	Setting of the output function for OUT1	28
10.5.2	Setting of switching limits (hysteresis function)	28
10.5.3	Setting of switching limits (window function)	28
10.5.4	Setting of the switch-off delay.....	29
10.5.5	Setting of the output function for OUT2 (analogue output)	29
10.5.6	Scaling of the analogue value	29
10.5.7	Response of the outputs in case of a fault	29
10.5.8	Setting of the delay time after signal loss.....	29
10.6	Reset of all parameters to factory setting	30
10.7	Changing basic settings	30
10.7.1	New entering of the probe length	30
10.7.2	Setting to another medium	30
10.7.3	New entering of the type of probe used.....	31
11	Operation	31
11.1	Operating indicators	31
11.2	Reading of the set parameters.....	31
11.3	Changing the display unit in the Run mode	32
11.4	Error indications	32
11.5	Remarks on application-related malfunction.....	33
11.6	Output response in different operating states	33
12	Scale drawing	34
13	Technical data.....	35
13.1	Setting ranges	36
14	Maintenance	37
15	Factory setting	38

1 Preliminary note

1.1 Symbols used

► Instruction

> Reaction, result

[...] Designation of pushbuttons, buttons or indications

→ Cross-reference



Important note

Non-compliance can result in malfunctions or interference.



Information

Supplementary note.

2 Safety instructions

- Please read this document prior to set-up of the unit. Ensure that the product is suitable for your application without any restrictions.
- The unit must be connected by a qualified electrician.
- The national and international regulations for the installation of electrical equipment must be adhered to.
- The unit complies with the standard EN 61000-6-4 and is a class A product. The radiated energy of the microwaves is, for example, much below that of mobile phones. According to the current state of science the operation of the unit can be classified to be harmless to human health.
- The unit may cause radio interference in domestic areas. If interference occurs, the user must take appropriate remedial actions.
- Improper or non-intended use may lead to malfunctions of the unit or to unwanted effects in your application. That is why installation, electrical connection, set-up, operation and maintenance of the unit must only be carried out by qualified personnel authorised by the machine operator.

For the scope of validity cULus → chapter 7 Electrical connection.

3 Items supplied

- Level sensor LR3000
- Operating instructions

In addition, the following is necessary for installation and operation:

- 1 rod (for operation of the unit with single probe→ 4.1)
- plus 1 coaxial pipe (for operation of the unit with coaxial probe→ 4.2)
- mounting material

The following components are available as accessories:

Rods	Length (cm / inch)	Order number
	24 / 9.5	E43203
	45 / 17.7	E43204
	70 / 27.6	E43205
	100 / 39.4	E43207
	120 / 47.2	E43208
	140 / 55.1	E43209
	160 / 63.0	E43210
Coaxial pipes with process connection G ³ / ₄	Length (cm / inch)	Order number
	24 / 9.5	E43211
	45 / 17.7	E43212
	70 / 27.6	E43213
	100 / 39.4	E43214
	120 / 47.2	E43215
	140 / 55.1	E43216
Coaxial pipes with process connection ³ / ₄ " NPT	Length (cm / inch)	Order number
	45 / 17.7	E43218
	70 / 27.6	E43219
	100 / 39.4	E43220
	160 / 63.0	E43221
Flange plates	Size / process connection	Order number
	73 - 90 / G ³ / ₄	E43201
	65 - 80 / G ³ / ₄	E43202
	73 - 90 / ³ / ₄ " NPT	E43206

UK



Only use rods and coaxial pipes from ifm electronic. The optimum function is not ensured when using components from other manufacturers.

For the correct function when used with single probe, the unit needs a large enough metal launching plate. The flange plates that are available as accessories are not sufficient as launching plates (for suitable launching plates → 6.4.1 / 6.4.2).

4 Functions and features

The unit continuously detects the level in tanks and generates output signals according to the parameter settings.

2 outputs are available: one analogue output and one switching output. They can be set separately..

4.1 Operation with single probe

The single probe is made up of one individual rod. Operation with single probe is suited for the detection of aqueous media, in particular of heavily soiled aqueous media.



For the correct function with single probe, the unit needs a large enough metal launching plate. It is necessary for transferring the microwave pulse to the tank with optimum transmission power.

For installation in closed metal tanks, the tank lid serves as a launching plate. For installation in open metal tanks, tanks made of plastic or metal tanks with plastic lids a sufficiently large fixing plate, a metal plate or similar must be used (→ 6.4.1 / 6.4.2).

For operation with single probe, minimum distances to tank walls, objects in the tank, bottom of the tank and further level sensors must be adhered to (→ 6.1.1).

4.2 Operation with coaxial probe

The coaxial probe is made up of an inner rod and an outer probe pipe (coaxial pipe). The rod is centered in the coaxial pipe by one or several spacers.

In case of operation with a coaxial probe media with a low dielectric constant (e.g. oil and oil-based media) are detected in addition to aqueous media.



No launching plate is required for operation with coaxial probe. Furthermore, no minimum distances to tank walls and objects in the tank are required.

4.3 Applications

- Water, water-based media
- Oils, oil-based media (only for operation with coaxial probe)
- Medium temperature: 0...80 °C (permanent); 0...90 °C (short-term)
- Tank pressures: -1...4 bar

Application examples:

- Detection of coolant emulsion in a machine tool.
- Detection of cleaning liquid in a parts cleaning system.
- Monitoring of hydraulic oil in a hydraulic power unit (only for operation with coaxial probe)

UK

Restriction of the application area

- The unit is not suitable for bulk materials (e.g. plastic granulates)
- If the unit is to be used in acids or alkalis, in hygienic areas or in electroplating applications: first check the compatibility of the product materials (→ chapter 13, Technical data) with the media to be monitored.
- Incorrect measurements or signal loss may be caused by the following media:
 - Highly absorbing surfaces (e.g. foam).
 - Intensely bubbling surfaces.
 - Media which are very inhomogeneous, separate from each other thus forming separation layers (e.g. oil layer on water).

Check the function by an application test.

In case of signal loss, the unit displays [E.033] and switches the outputs to a defined state (→ 11.5).

- The unit is not suitable for applications where the probe is subjected to permanent and high mechanical stress (e.g. strongly moving viscous media or strongly flowing media).
- In case of operation with single probe: use preferably in metal tanks. When installed in plastic tanks, deterioration caused by electromagnetic interference may occur (noise immunity to EN61000-6-2). Remedy: → 6.4.2.
- In case of operation with coaxial probe: not suitable for viscous media and media prone to formation of deposit.

5 Function

5.1 Measuring principle

The unit operates to the principle of guided wave radar. It measures the level using electromagnetic pulses in the nanosecond range.

The pulses are transmitted by the sensor head and guided along the rod (fig. 1). When they hit the medium to be detected they are reflected and guided back to the sensor (fig. 2). The time between transmitting and receiving the pulse directly relates to the travelled distance (D) and the current level.

The reference for distance measurement is the lower edge of the process connection.

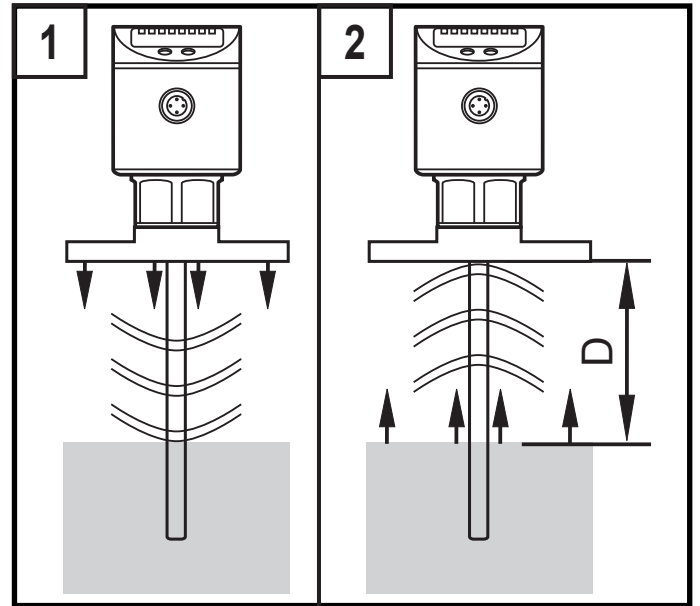

The figure shows operation with single probe.
In case of operation with a coaxial probe, the guided wave runs along the inside of the coaxial pipe.

5.2 Features of the unit

Easy set-up

- When the unit is supplied with operating voltage for the first time, the probe length, the medium to be detected and the type of probe used must be entered. After this, the unit is operational. (→ 10.2).
- If necessary, parameters for the output signals and optimisation of the monitoring functions can be set (→ 10.3 to 10.5).
- All settings can also be carried out before installation of the unit.
- Reset to the factory settings is possible.
- Electronic lock can be set to prevent unintentional operations.

Display functions

- The unit displays the current level, either in cm, inch or in percent of the final value of the measuring range. Factory setting: cm. The display unit is defined by programming (→ 10.3). In the Run mode, it can be temporarily switched between length indication (cm / inch) and percentage:
 - ▶ Press [Set] briefly.
 - >The selected unit is displayed for 15 s, the corresponding LED is lit.With each push of the button the display type is changed.

- The set unit of measurement and the switching status of the outputs are indicated by LEDs.

Analogue function

The unit provides an analogue signal proportional to level. The analogue output (OUT2) can be set as current or voltage output:

- Current output analogue 4...20 mA ([OU2] = [I]); voltage output analogue 0...10 V ([OU2] = [U]).
- The analogue start point [ASP] determines at which measured value the output signal is 4 mA or 0 V.
- The analogue end point [AEP] determines at which measured value the output signal is 20 mA or 10 V.

UK

Minimum distance between [ASP] and [AEP] = 25 % of the active zone.

Curve of the analogue signal:s (Factory setting):

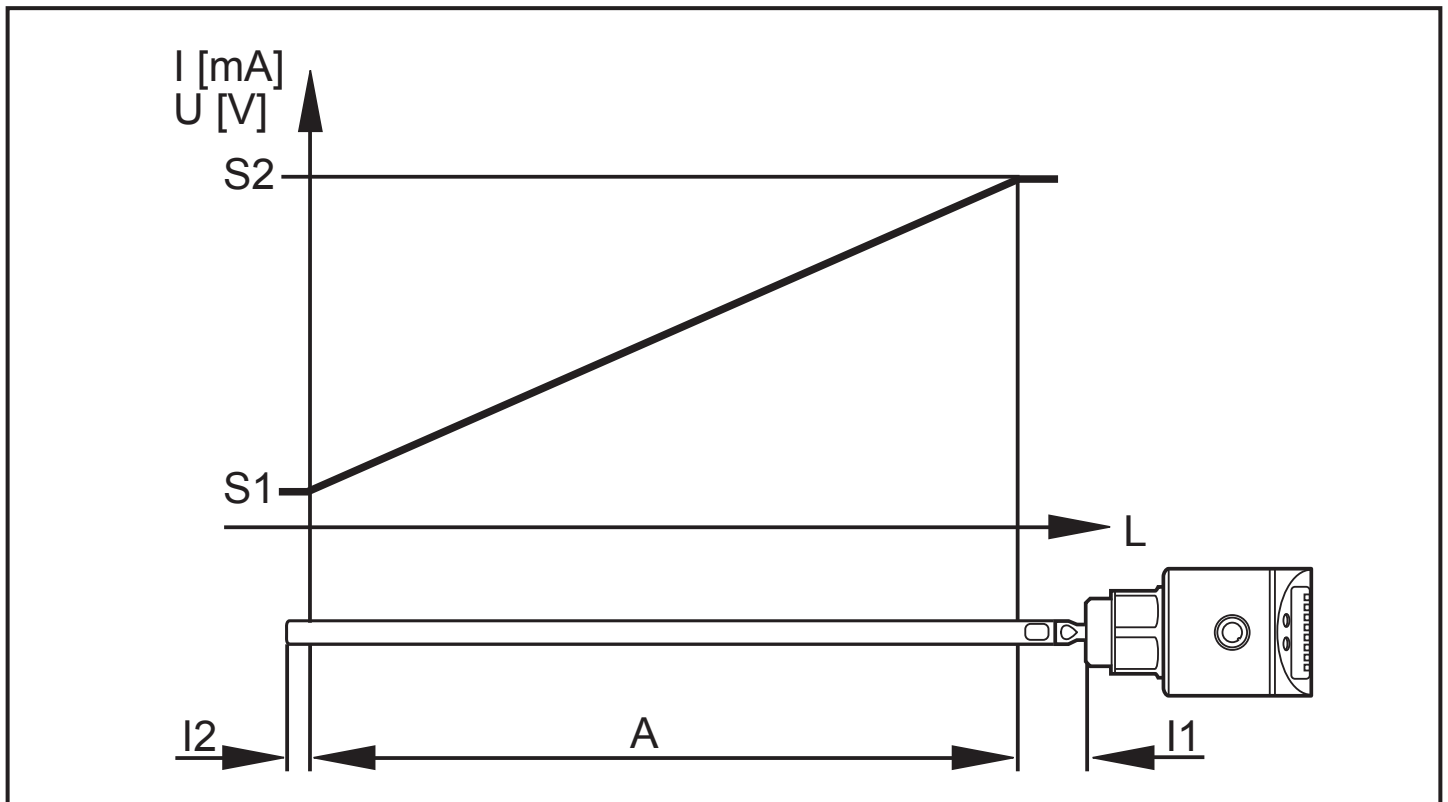

L = level

A = active zone; $I1$ = inactive zone 1; $I2$ = inactive zone 2 (→ 12 Scale drawing)

$S1$ = zero signal (4 mA / 0 V); $S2$ = full signal (20 mA / 10 V)

Note the tolerances and accuracy limits during the evaluation of the analogue signal (→ 13 Technical data).

Curve of the analogue signal: (Measuring range scaled):

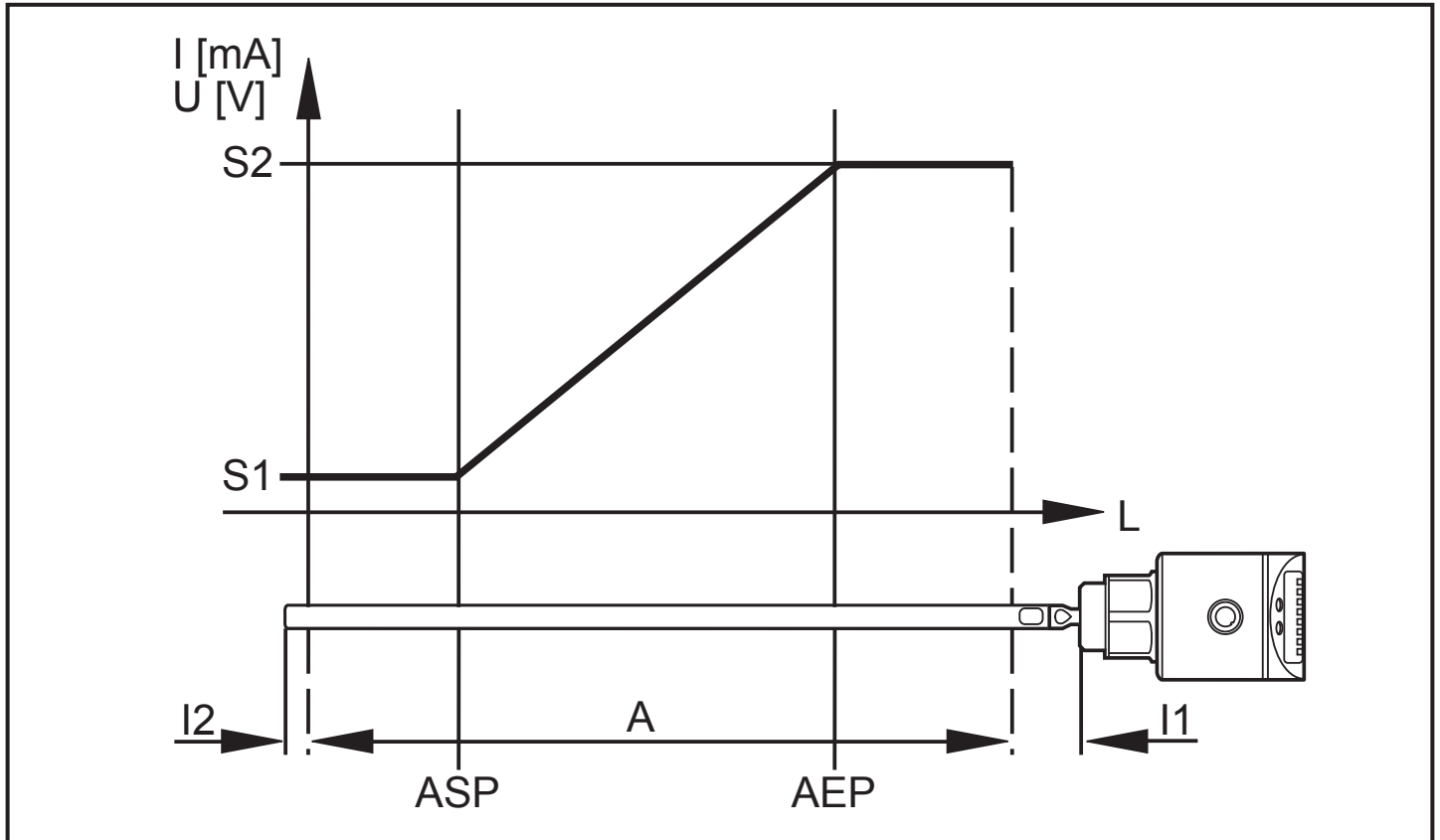

L = level; ASP = analogue start point; AEP = analogue end point

A = active zone; I1 = inactive zone 1; I2 = inactive zone 2 (→ 12 Scale drawing)

S1 = zero signal (4 mA / 0 V); S2 = full signal (20 mA / 10 V)

Note the tolerances and accuracy limits during the evaluation of the analogue signal (→ 13 Technical data).

Switching functions

The unit signals via the switching output OUT1 that a set limit level has been reached or that the level is below the limit value.

For the output the following switching functions can be selected:

- Hysteresis function / normally open (figure 1): [OU1] = [Hno].
- Hysteresis function / normally closed (figure 1): [OU1] = [Hnc].

First the set point (SP1) is set, then the reset point (rP1) with the requested difference.

- Window function / normally open (figure 2): [OU1] = [Fno].
- Window function / normally closed (figure 2): [OU1] = [Fnc].

The width of the window can be set by means of the difference between FH1 and FL1. FH1 = upper value, FL1 = lower value.

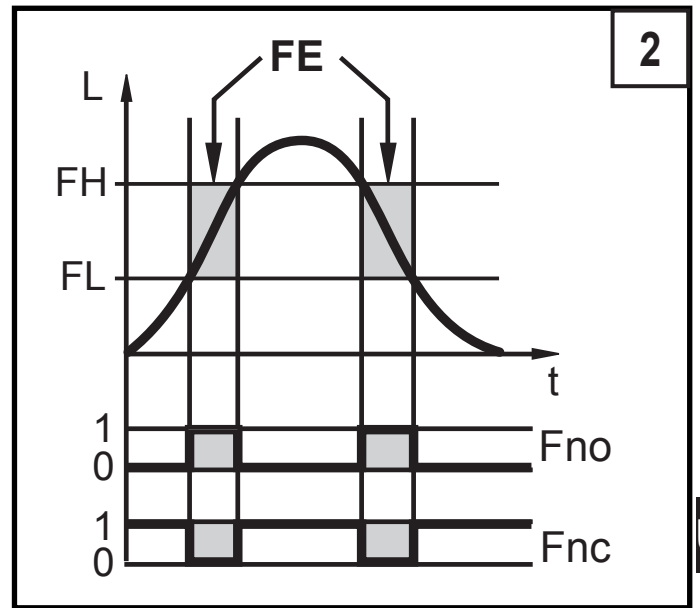
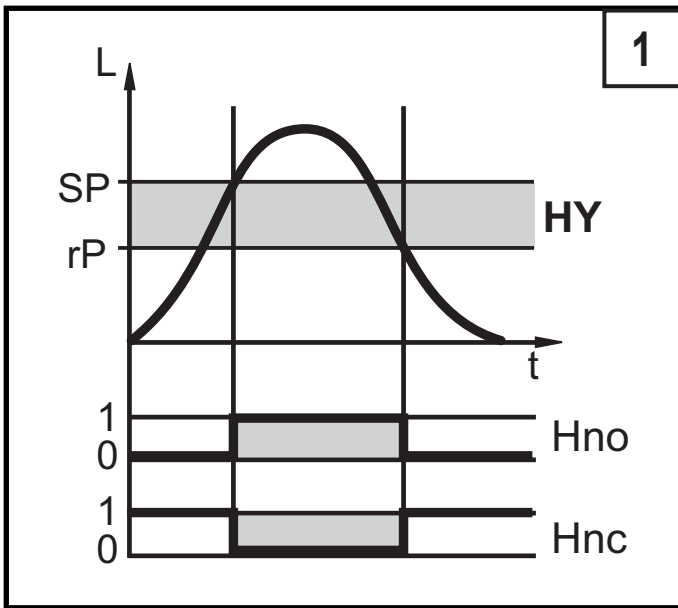

L = level; HY = hysteresis; FE = window

- For the switching output a switch-off delay of max. 5 s can be set (e.g. for especially long pump cycles).

Offset for indicating the real level in the tank

The zone between tank bottom and lower edge of the probe can be entered as offset value [OFS]. So display and switch points refer to the actual level.

Probes for different tank heights

- The unit can be installed in tanks of different sizes. Probes in different lengths are available. To adapt to the tank height, each probe can be shortened. The minimum probe length is 10 cm, the maximum probe length is 160 cm.
- Probe and housing can be rotated without restriction. This enables easy installation and orientation of the head of the unit after installation.

Safe state

- In case of a fault a safe state can be defined for each output.
- If a fault is detected or if the signal quality is below a minimum value, the outputs pass into the "safe state". For this case the response of the outputs can be set via the parameters [FOU1], [FOU2].
- Temporary loss of signal caused e.g. by turbulence or foam formation can be suppressed by a delay time (\rightarrow 10.5.8 [dFo]). During the delay time the last measured value is frozen. If the measured signal is received again with sufficient strength within the delay time, the unit continues to work in normal operation. If, however, it is not received again with sufficient strength within the delay time, the outputs pass into the safe state.

6 Installation

6.1 Installation location / environment

- Vertical installation from the top is preferred.

6.1.1 Unit with single probe

- For a safe function, the unit requires a launching plate (→ 6.4).
- For optimum operation the unit should be installed as near as possible to the tank wall. Distance between the rod and the tank wall: minimum 40 mm, maximum 300 mm.
- The following minimum distances between the rod and tank walls, objects in the tank (B), tank bottom and other level sensors must be adhered to:

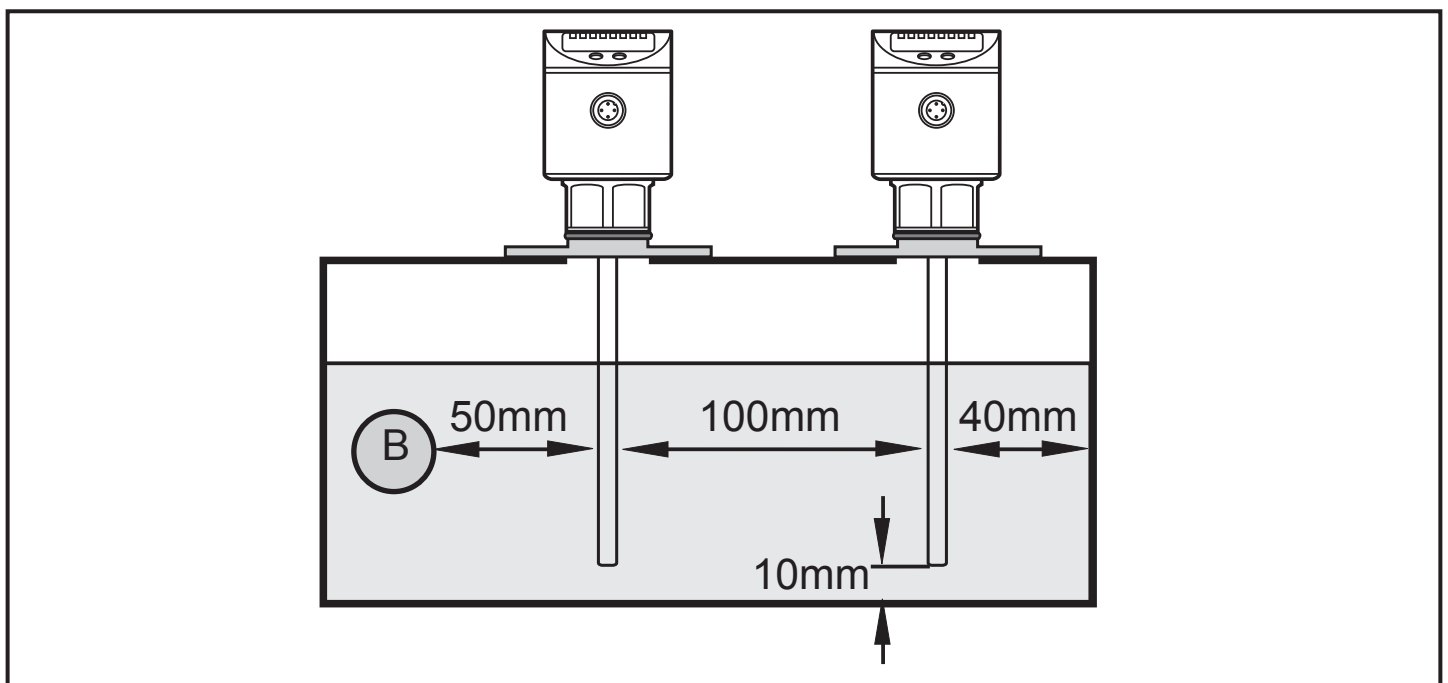

- For tank walls which are not straight, steps, supports or other structures in the tank a distance of 50 mm to the tank wall must be adhered to.
- For rod lengths > 70 cm the rod can be considerably deflected by movement of the medium. To avoid contacting the tank wall or other structures in the tank in such cases, the minimum distances should be increased. Reference values:

Rod length	Distance to the tank wall or structures in the tank
70...100 cm	100 mm
100...160 cm	180 mm

- If the medium is strongly polluted, there is the risk that a bridge forms between the rod and the tank wall or structures in the tank. To avoid incorrect measurements: adhere to increased minimum distances depending on type and intensity of the soiling.

- For installation in pipes:
 - The inside pipe diameter (d) must be at least 100 mm.
 - Only install the unit in metal pipes.
- For installation in connection pieces:
 - The diameter of the connection piece (d) must be at least 50 mm.
 - The height of the connection piece (h) must not exceed 40 mm.

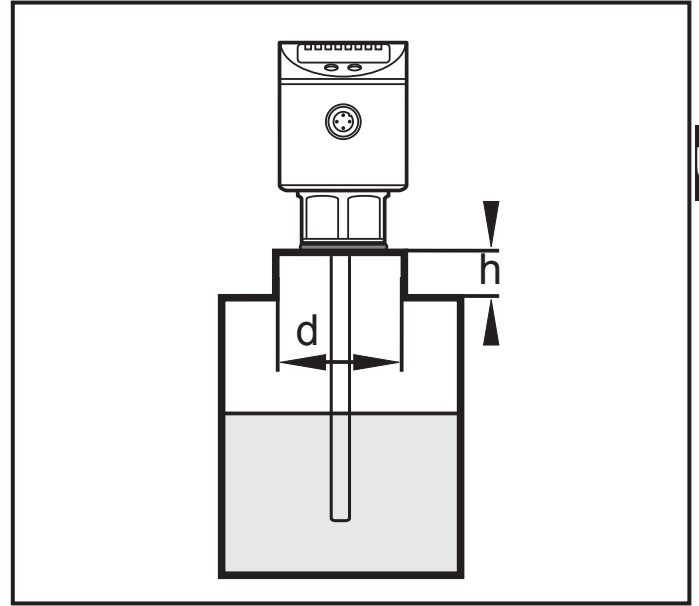
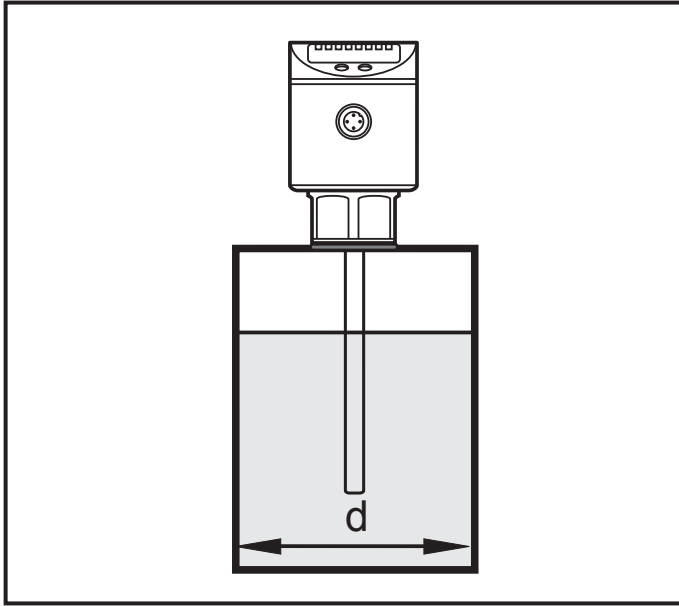

UK

- The maximum level must not exceed the limit of the block distance (BD = 30 mm). If it is exceeded by more than 10 mm, malfunctions can occur.
Remedies: arrange for a spout; install the unit in a connection piece.

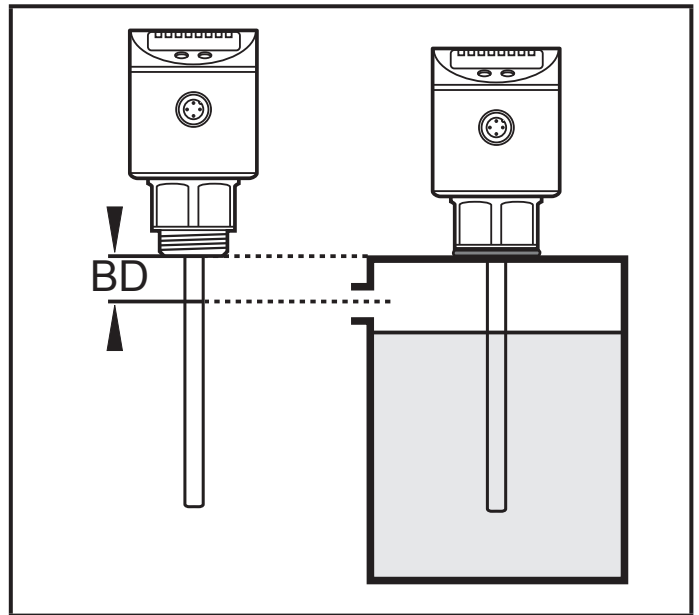

- Do not install the unit in the immediate vicinity of a fill opening. If possible, install a fill pipe (A) in the tank. Minimum distance between the fill pipe and the rod = 50 mm; higher for rod lengths > 70 cm and in case of heavy soiling (→ 6.1.1).

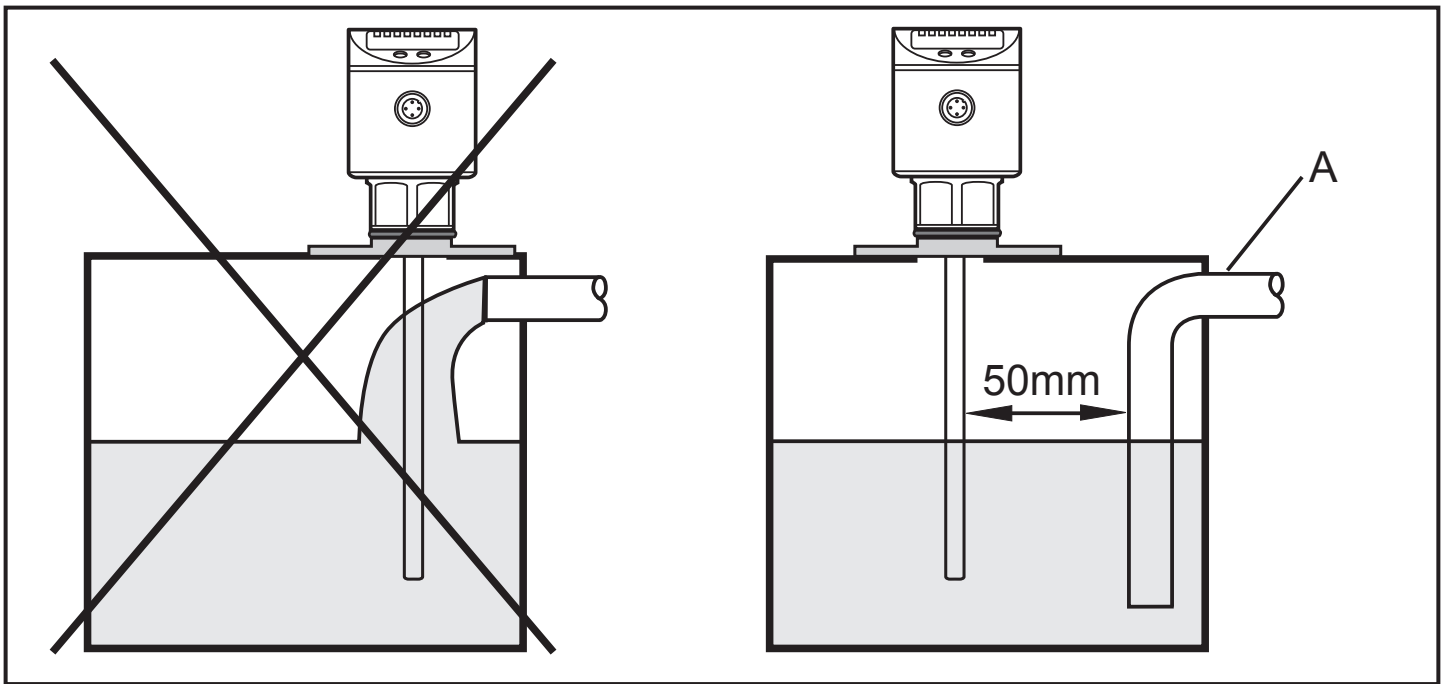

- Strong foam formation and strongly moving surfaces can lead to malfunctions. Recommended remedies: use a coaxial probe, install a still pipe or bypass. Note: minimum diameter $d = 100$ mm. The upper access to the bypass (A) and the fill openings of the still pipe (B) must be above the maximum level. The lower edges of the bypass (C) and of the still pipe (D) must be below the minimum level. This ensures that neither foam nor waves impact the sensor zone.

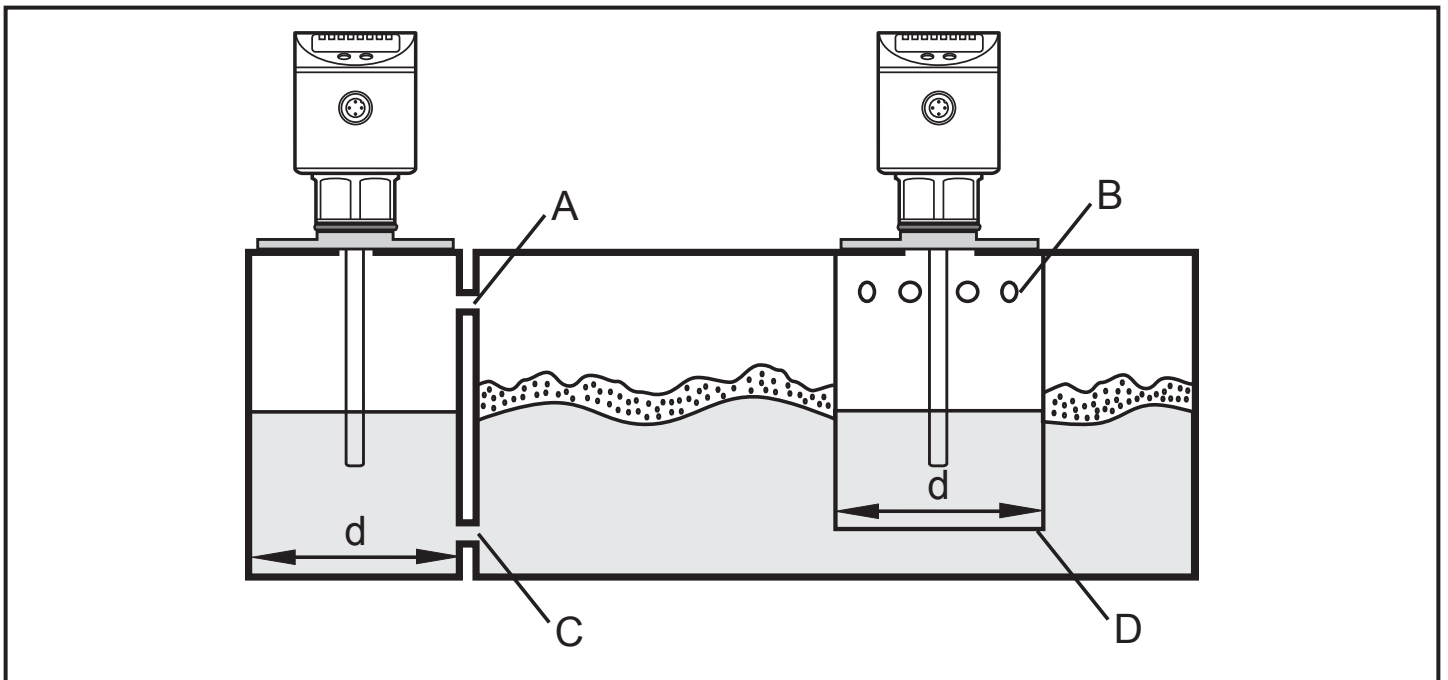

6.1.2 Unit with coaxial probe

- There are no minimum distances to the tank wall and the baffles (B) required.
- Minimum distance to the bottom of the tank: 10 mm.
- The vent hole (A) must not be covered by mounting elements or similar.
- Do not install the unit in the immediate vicinity of a fill opening. No water jets must enter into the holes of the coaxial pipe.

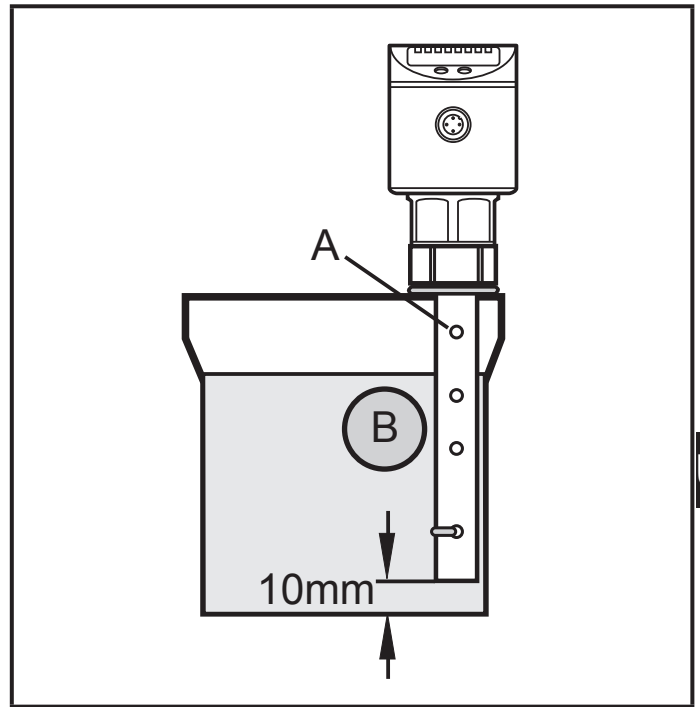

UK

- Note in case of foam formation: the vent of the coaxial pipe must be above the maximum level. The lowest opening of the coaxial pipe must be below the minimum level.

6.2 Installation of the probe

Rod and coaxial pipe are not included in the scope of delivery. They must be ordered separately (→ 3 Items supplied).

6.2.1 Installation of the rod

Fixing of the rod:

- Screw the rod to the unit and tighten it.

Recommended tightening torque:
4 Nm.

For ease of installation and removal the rod connection can be rotated without restriction. Even if rotated several times there is no risk of damage to the unit.

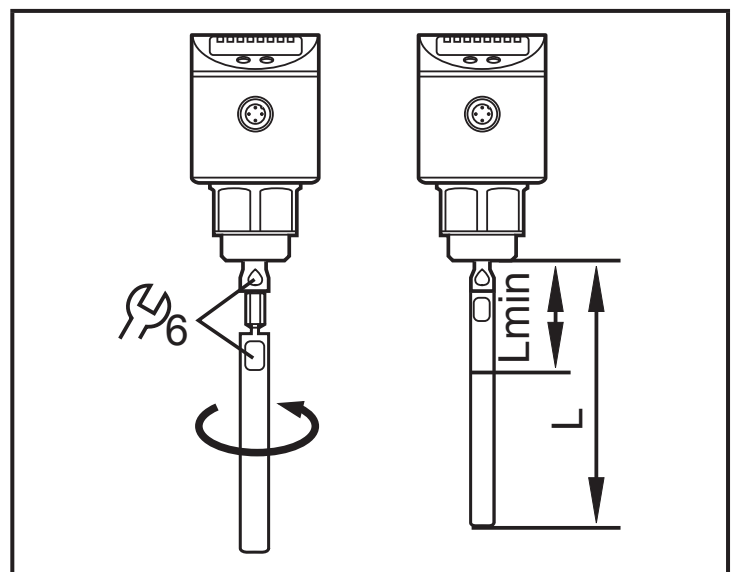

$L_{min} = 10 \text{ cm}$

In case of high mechanical stress (strong vibration, moving viscous media) it may be necessary to secure the screw connection, e.g. by a screw retaining com-

pound. Note: such substances may migrate into the medium. Make sure that they are harmless.

When using mechanical means of securing (e.g. tooth lock washer), protruding edges must be avoided. They may cause interference reflection.

6.2.2 Installation of the coaxial pipe

(only necessary if the unit is to be operated with coaxial probe)



The coaxial pipe and the rod must be of the same end length. The coaxial pipe can be shortened (→ 6.3.2).

- ▶ Screw the rod to the unit and tighten it. Recommended tightening torque: 4 Nm.
- ▶ Slide the sensor sealing (A) onto the thread.
- ▶ Slide the coaxial pipe (B) onto the rod. Carefully center it and carefully move the rod through the centring piece (C) (for lengths > 140 cm through both centring pieces) of the coaxial pipe. Do not damage the centring pieces.
- ▶ Screw onto the sensor thread and tighten.

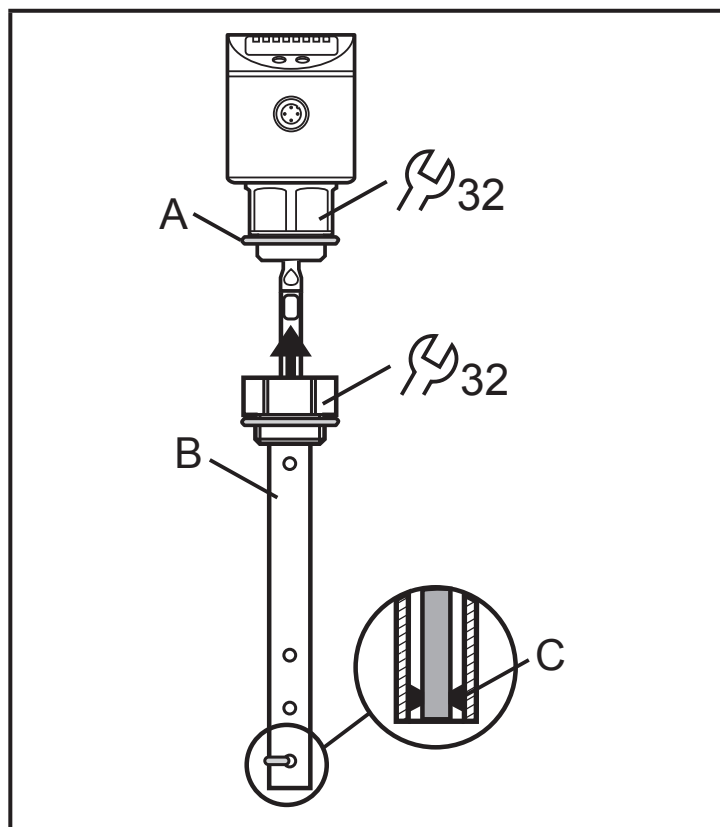

6.3 Shortening of the probe

6.3.1 Shortening of the rod

The rod can be shortened to adapt to different tank heights. NOTE: ensure that the rod length is not below the minimum permissible length of 10 cm (L_{min}).

Proceed as follows:

- ▶ Screw the rod to the unit.
- ▶ Mark the desired length (L) on the rod. The reference point is the lower edge of the process connection.
- ▶ Remove the rod from the unit.
- ▶ Shorten the rod.
- ▶ Remove all burrs and sharp edges.

- ▶ Screw the rod to the unit again and tighten it. Recommended tightening torque: 4 Nm.
- ▶ Precisely measure the rod length L , note the value. It must be entered during parameter setting of the unit (\rightarrow 10. 2).

6.3.2 Shortening of the coaxial pipe

The coaxial pipe and the rod must be of the same end length.

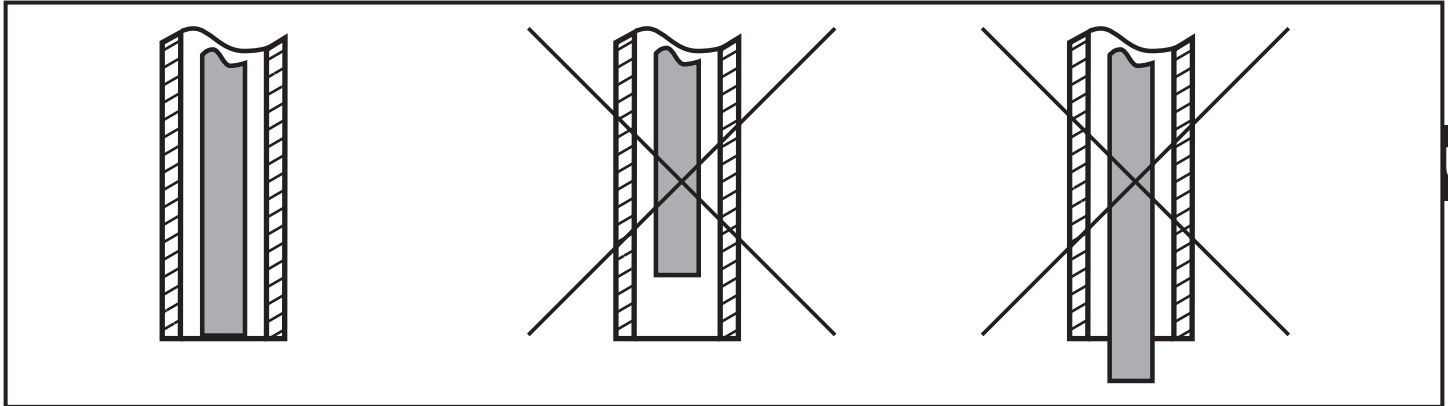

UK

- ▶ Remove fastening bracket and centring piece (A, B).
- ▶ Shorten the coaxial pipe to the requested length: $L_K = L + 9$ mm. After shortening, at least one hole (C) for insertion of the fixing bracket has to be left.
- ▶ Remove all burrs and sharp edges.
- ▶ Insert centring piece (A) at the lower end of the pipe and attach it using the fixing bracket (B) at the lower hole (C).

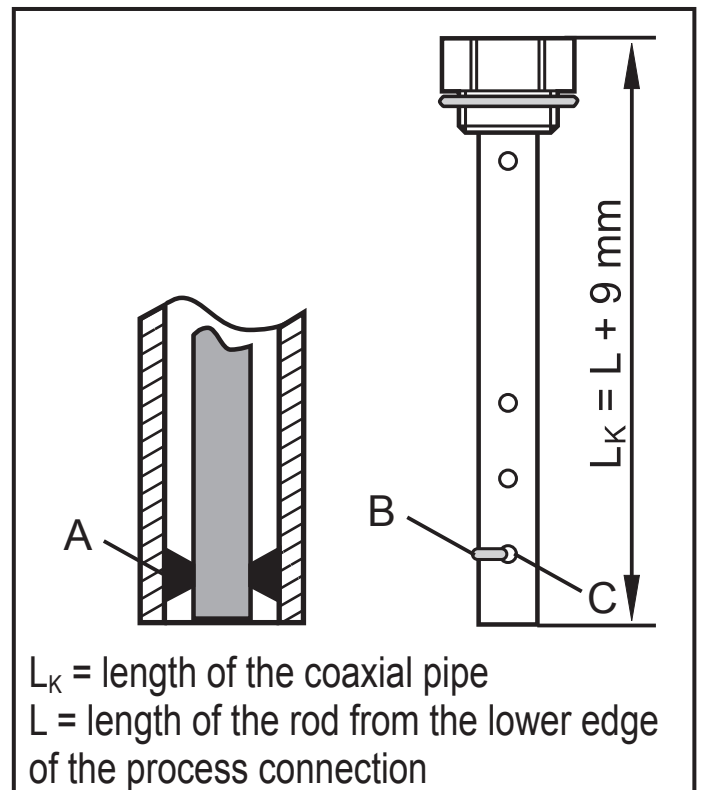

6.4 Installation of the unit with single probe

6.4.1 Installation in metal tanks

NOTE: In all cases the unit needs a metal surface to transfer the measured signals (launching plate). For installation in closed metal tanks, the metal lid serves as a launching plate (R).

2 ways of installation are possible:

- Screw in a $G^{3/4}$ process connection in the tank lid (fig. A).

- Installation in the tank lid using a flange plate e.g. for tanks with thin walls (fig. B).

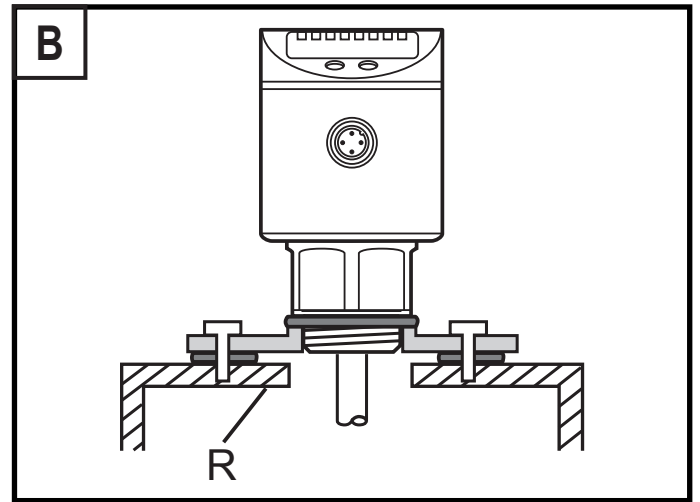
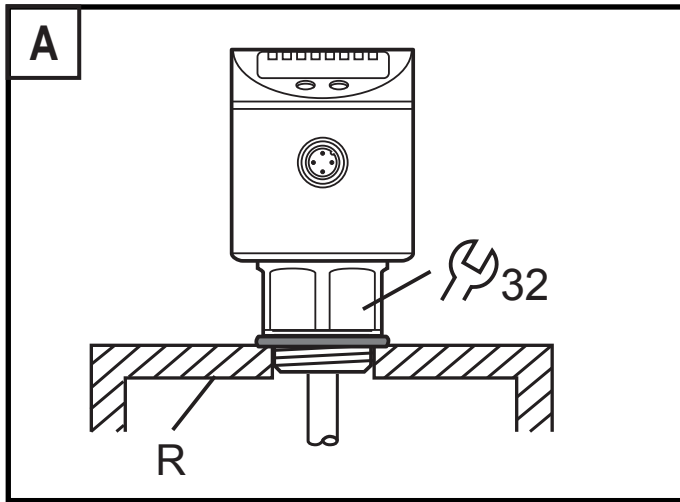

For installation in open tanks, the unit must be installed using a metal fixture. It serves as a launching plate (R). Minimum size: 150 x 150 mm for a square fixture, 150 mm diameter for a circular fixture. If possible, mount the unit in the middle of the fixture. The distance D2 must not be below 40 mm (fig. C); higher for rod lengths > 70 cm and in case of heavy soiling (→ 6.1.1).

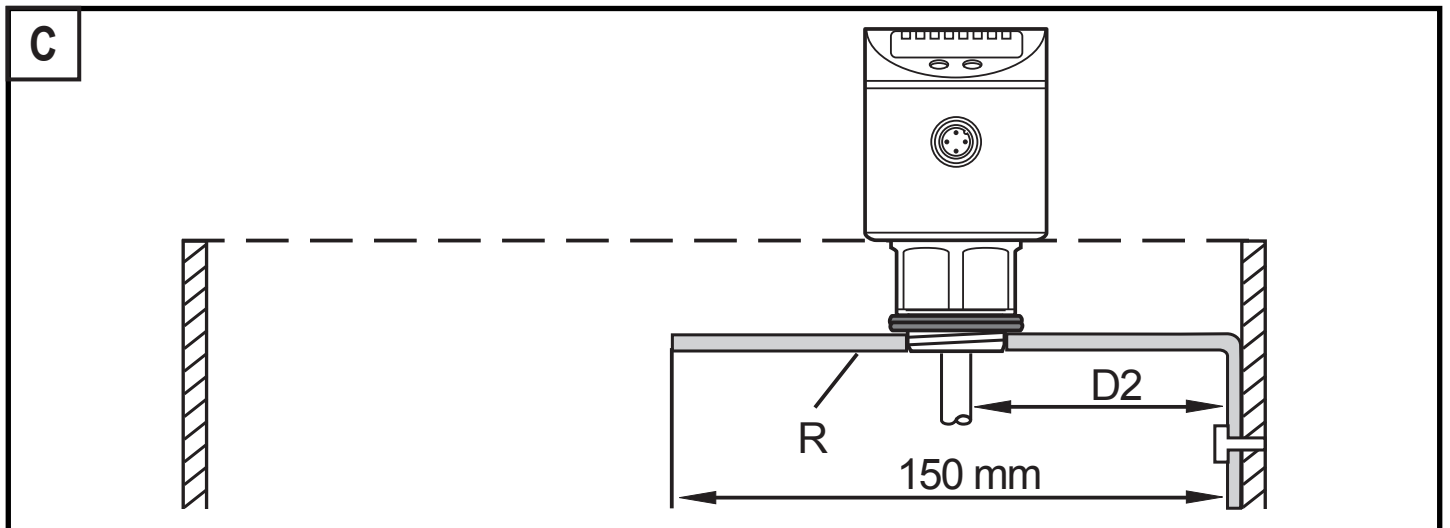

The lower edge of the process connection should be flush with the installation environment. Use seals or washers (D) to reach the required height. When using the ifm flange plates flush installation is ensured.

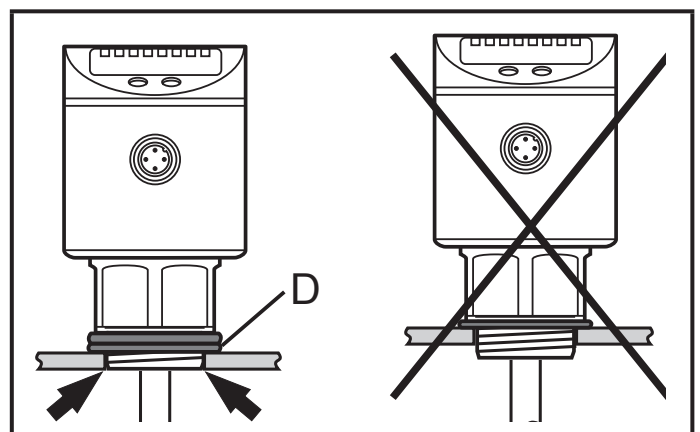

6.4.2 Installation in plastic tanks

To enable sufficient transfer of the measured signal, note in case of installation in plastic tanks or metal tanks with plastic lid:

- A drill hole with a minimum diameter of 150 mm must be applied to the plastic lid.
- For installation of the unit, a flange plate (= launching plate R) must be used which sufficiently covers the drill hole.

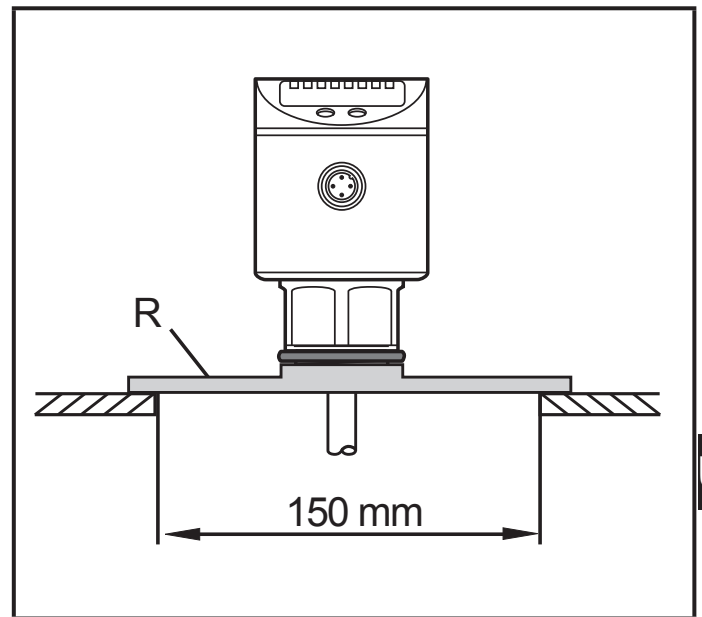

Minimum distance between rod and tank wall = 80 mm, higher for rod lengths > 70 cm and in case of heavy soiling (→ 6.1.1).



When installed in plastic tanks, there may be deterioration caused by electromagnetic interference. Remedy:

- Apply a metal foil to the outside of the tank.
- Apply a shielding screen between the level sensor and other electronic units.
- Operation with coaxial probe efficiently protects the unit from electromagnetic interference. Please note the restrictions regarding the application area (→ 4.3).

6.4.3 Installation using a flange plate

Flange plates are not included in the scope of delivery. They must be ordered separately (→ chapter 3).

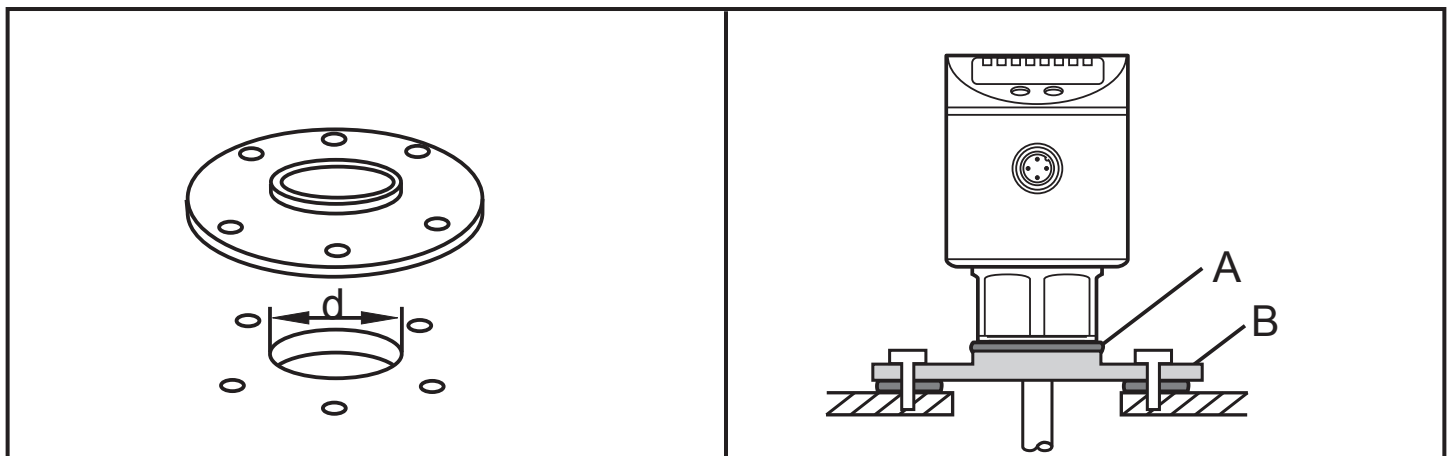

- ▶ Arrange for a bore hole in the tank lid. It must have a minimum diameter (d) to enable sufficient transfer of the measured signal to the probe. The diameter depends on the wall thickness of the tank lid:

Wall thickness [mm]	1...5	5...8	8...11
Bore hole diameter [mm]	35	45	55

- ▶ Install the flange plate with the flat surface showing to the tank and fix it with appropriate screws.
A seal (B) can be inserted between flange plate and tank (some flange plates are supplied with seal).
- ▶ Ensure cleanness and evenness of the sealing areas, especially if the tank is under pressure. Tighten the fixing screws sufficiently.
- ▶ Screw the unit in the flange plate and tighten firmly.
- ▶ Make sure that the supplied sensor seal (A) is correctly positioned.

6.5 Installation of the unit with coaxial probe in the tank

- ▶ Seal the process connection.
 - For pipes with G³/₄ process connection: slide the supplied seal onto the thread of the coaxial pipe.
 - For pipes with G³/₄“ NPT process connection: apply a suitable sealing material (e.g. Teflon tape).
- ▶ Screw the sensor with the coaxial pipe into the tank and tighten it.



After installation, the sensor housing can be aligned. It can be rotated without restriction. Even if rotated several times there is no risk of damage to the unit.

7 Electrical connection



The unit must be connected by a qualified electrician.

The national and international regulations for the installation of electrical equipment must be adhered to.

Voltage supply according to EN 50178, SELV, PELV.

For the scope of validity cULus:

The device shall be supplied from an isolating transformer having a secondary Listed fuse rated as noted in the following table.

Overcurrent protection		
Control-circuit wire size		Maximum protective device rating Ampere
AWG	(mm ²)	
26	(0.13)	1
24	(0.20)	2
22	(0.32)	3
20	(0.52)	5
18	(0.82)	7
16	(1.3)	10

UK

- ▶ Disconnect power.
- ▶ Connect the unit as follows:

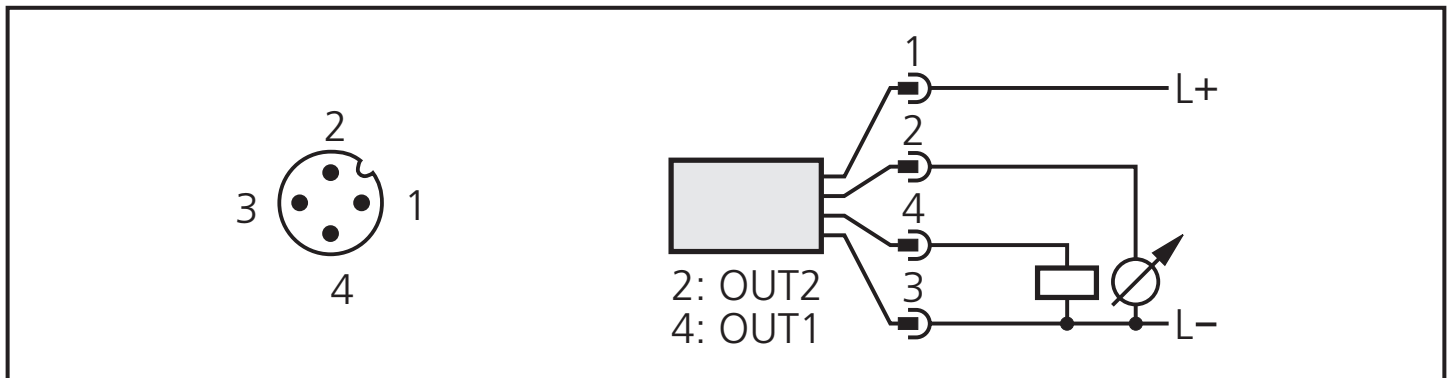

Pin / connection	Core colours for ifm sockets
1 L+	brown
2 OUT2 (analogue output)	white
3 L-	blue
4 OUT1 (switching output)	black

Note: when the unit is supplied with operating voltage for the first time, the probe length, the medium to be detected and the type of probe used must be entered. After this, the unit is operational (→ 10.2).

8 Operating and display elements

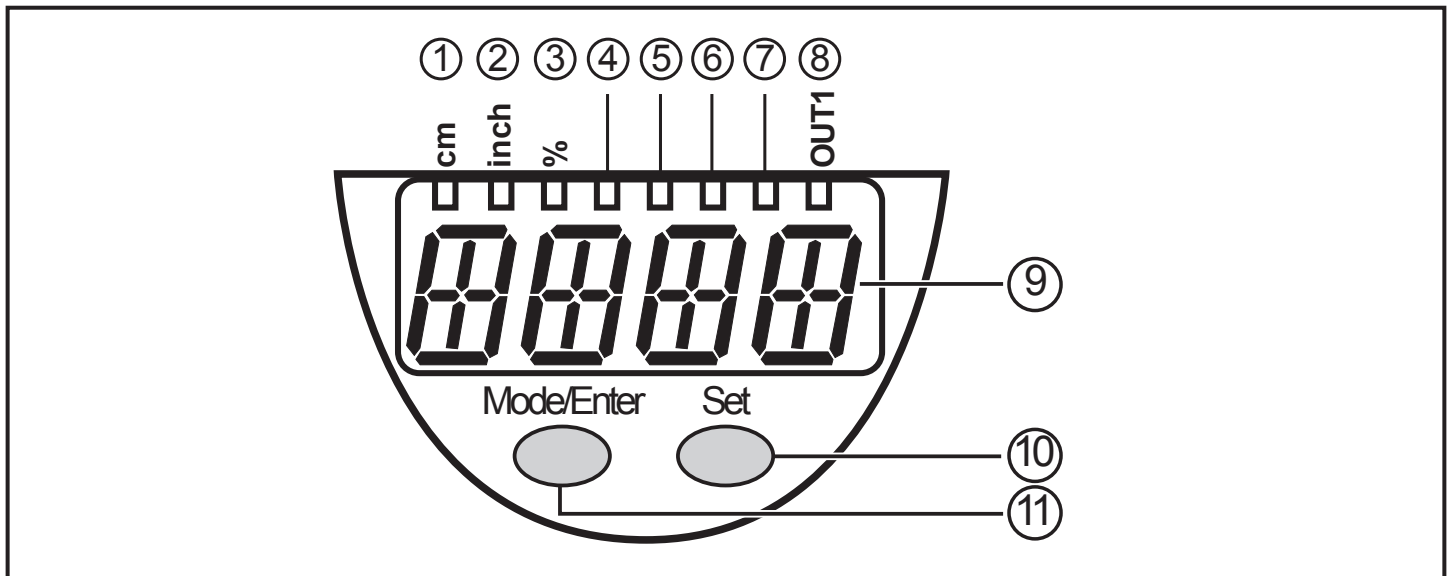

1 to 8: indicator LEDs

- LED 1: green = indication of the level in cm.
- LED 2: green = indication of the level in inch.
- LED 3: green = indication of the level in % of the final value of the measuring range.
- LED 4 - LED 7: not used.
- LED 8: yellow = output 1 is switched.

9: Alphanumeric display, 4 digits

- Indication of the current level.
- Operation and fault indication.
- Indication of the parameters and parameter values.

10: Set button

- Setting of the parameter values (scrolling by holding pressed; incrementally by pressing once).
- Change between cm/inch indication and percent indication in the normal operating mode (Run mode).

11: Mode/Enter button

- Selection of the parameters and acknowledgement of the parameter values.

9 Menu

9.1 Menu structure

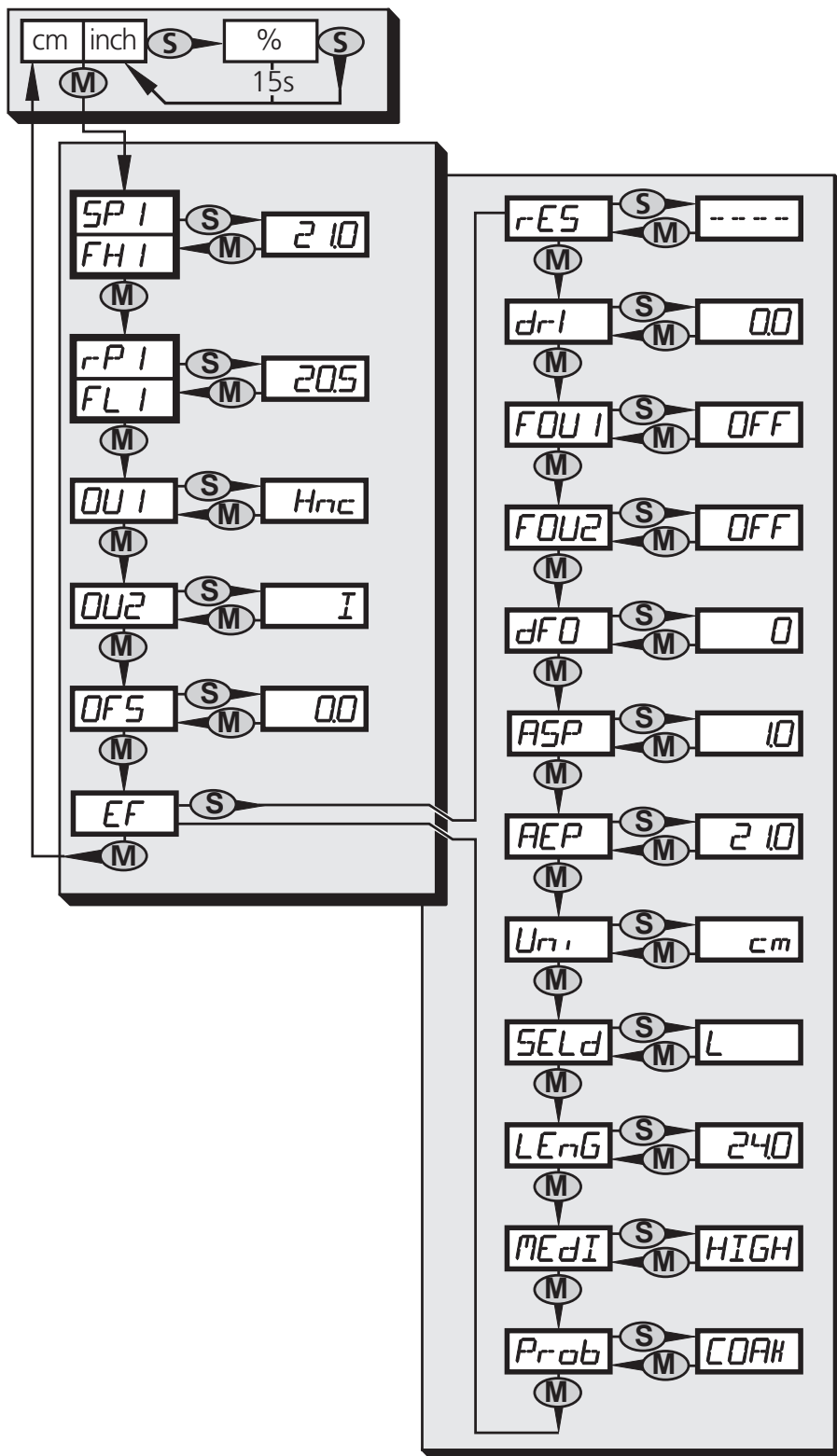

UK

9.2 Explanation of the menu

SP1/rP1	Upper / lower limit value for the level at which OUT1 switches.
FH1/FL1	Upper / lower limit for the acceptable range (monitored by OUT1).
OU1	Output function for OUT1: <ul style="list-style-type: none"> Switching signal for the level limit values: hysteresis function [H ..] or window function [F ..], either normally open [. no] or normally closed [. nc].
OU2	Output function for analogue output (OUT2): current or voltage output: $I = 4...20 \text{ mA} / U = 0...10 \text{ V}$.
OFS	Offset value for level measurement
EF	Extended functions / opening of menu level 2.
rES	Restore factory settings.
dr1	Switch-off delay for OUT1. The menu item is only active if OU1 = Hno or Hnc.
FOU1	Response of OUT1 in case of a fault.
FOU2	Response of OUT2 in case of a fault.
ASP	Analogue start value for the level; measured value at which 4 mA / 0 V is provided.
AEP	Analogue end value for the level; measured value at which 20 mA / 10 V is provided.
dFo	Delay time for switching response OUTx.
Uni	Unit of measurement (cm or inch).
SELd	Type of indication.
LEnG	Length of the rod.
MEdI	Medium to be detected.
Prob	Type of probe used (single probe or coaxial probe). The menu item is only active if MEdI = HIGH.

10 Parameter setting

During parameter setting the unit remains in the operating mode internally. It continues its monitoring function with the existing parameters until the parameter setting has been completed.

10.1 General parameter setting

3 steps must be taken for each parameter setting:

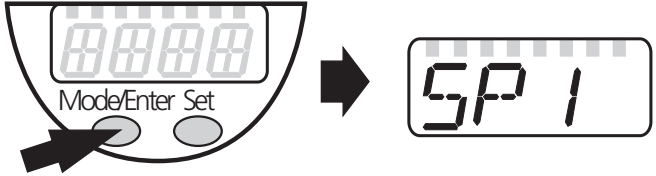
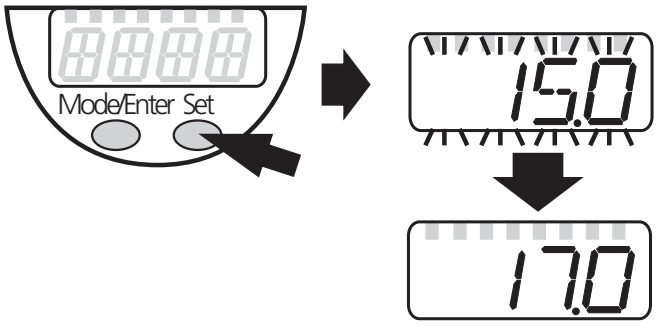
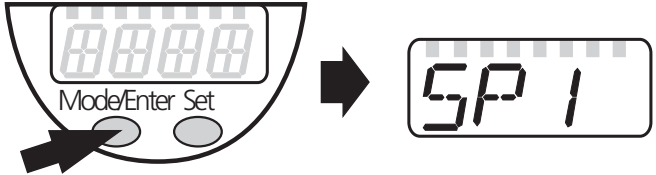
<p>1</p>	<p>Selection of the parameter</p> <ul style="list-style-type: none"> ▶ Press [Mode/Enter] until the requested parameter is displayed.. 	
<p>2</p>	<p>Setting of the parameter value</p> <ul style="list-style-type: none"> ▶ Press [SET] and keep it pressed. > Current setting value of the parameter flashes for 5 s. > After 5 s: setting value is changed: incrementally by pressing the button once or continuously by keeping the button pressed. 	
<p>Numerical values are incremented continuously. For reducing the value: let the display move to the maximum setting value. Then the cycle starts again at the minimum setting value.</p>		
<p>3</p>	<p>Acknowledgement of the parameter value</p> <ul style="list-style-type: none"> ▶ Press [Mode/Enter] briefly. > The parameter is displayed again. The new setting value is stored. 	
<p>Setting of other parameters:</p> <ul style="list-style-type: none"> ▶ Start again with step 1. 		
<p>Finishing the parameter setting:</p> <ul style="list-style-type: none"> ▶ Press [Mode/Enter] several times until the current measured value is displayed or wait for 15 s. > The unit returns to the operating mode. 		

UK

- Change from menu level 1 to menu level 2:

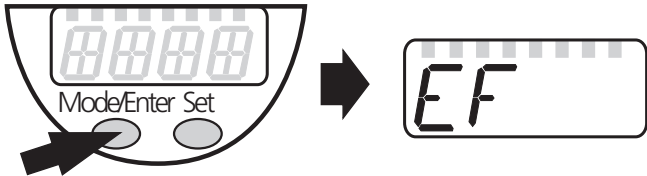
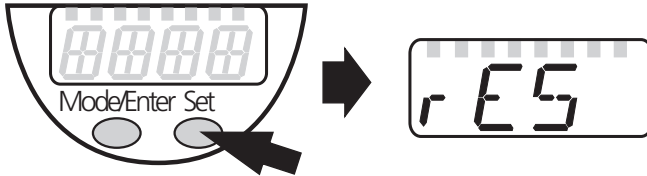
<ul style="list-style-type: none"> ▶ Press [Mode/Enter] until [EF] is displayed. 	
<ul style="list-style-type: none"> ▶ Press [Set] briefly. > The first parameter of the submenu is displayed (here: [res]). 	

- Locking / unlocking

The unit can be locked electronically to prevent unintentional settings.

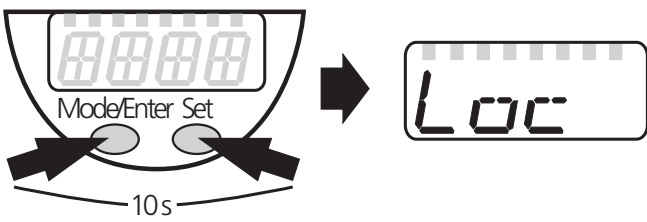
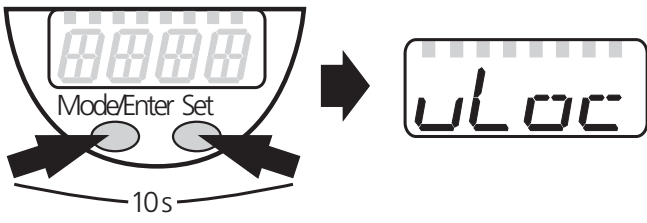
<ul style="list-style-type: none"> ▶ Make sure that the unit is in the normal operating mode. ▶ Press [Mode/Enter] + [Set] for 10 s. > [Loc] is displayed. 	
<p>During operation: > [Loc] is briefly displayed if you try to change parameter values.</p>	
<p>For unlocking:</p> <ul style="list-style-type: none"> ▶ Press [Mode/Enter] + [Set] for 10 s. > [uLoc] is displayed. 	

On delivery: unlocked.

- Timeout:

If no button is pressed for 15 s during parameter setting, the unit returns to the operating mode with unchanged values.

10.2 Basic settings (unit on delivery)

On delivery of the unit, you must first enter the basic settings. The complete parameter setting menu cannot be accessed before this.



Malfunctions may occur if wrong basic settings are entered.

10.2.1 Entering the probe length

<ul style="list-style-type: none">▶ Apply operating voltage.> The initial display <code>====</code> is shown.▶ Change to menu level 2.▶ Select [LEnG], press [SET] for 5 s.> [nonE] is displayed.▶ Enter the probe length in cm. Remarks on the determination of the probe length. → 10.7.1.▶ Press [Mode/Enter] briefly.	<code>LEnG</code>
---	-------------------

UK

10.2.2 Setting to the medium

<ul style="list-style-type: none">▶ Select [MEdI], press [SET] for 5 s.> [nonE] is displayed.▶ Set the requested value:<ul style="list-style-type: none">- [HIGH] for water and water-based media.- [LOW] for oils and oil-based media. <p>Note: In case of doubt, carry out an application test to ensure the setting which is best for your medium.</p>	<code>MEdI</code>
---	-------------------

10.2.3 Entering the type of probe used

<ul style="list-style-type: none">▶ Select [Prob], press [SET] for 5 s.> [nonE] is displayed.▶ Set the requested value:<ul style="list-style-type: none">- [rod] for single probe.- [COAX] for coaxial probe.• The detection of water and water-based media is possible with the single probe as well as with the coaxial probe.• The detection of oils and oil-based media is only possible with the coaxial probe. Therefore the value [COAX] is preset for the parameter [Prob] when setting [MEdI] = [LOW]; the value [rod] is not available.	<code>Prob</code>
---	-------------------

Then the unit changes to the operating mode. For further parameter setting the menu can be opened. The parameters [LEnG], [MEdI] and [Prob] can be accessed and modified just like all other parameters.

10.3 Configuration of the display

<ul style="list-style-type: none"> ▶ Select [Uni] and set the unit of measurement: [cm], [inch]. Factory setting: cm. ▶ Select [SELD] and set type of indication: <ul style="list-style-type: none"> - [L] = The level is indicated in cm or inch. - [L%] = The level is indicated in percent of the final value of the measuring range. - [OFF] = The display is switched off in the operating mode. When one of the buttons is pressed the current measured value is displayed for 15 s. The LEDs remain active even if the display is deactivated. 	
---	---

10.4 Offset setting

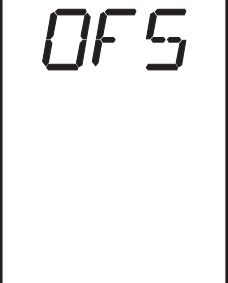

<ul style="list-style-type: none"> ▶ Select [OFS] and enter the distance between bottom of the tank and lower edge of the probe. Afterwards, display and switch points refer to the real level. Factory setting: [OFS] = 0. Note: Set [OFS] before setting the switching limits (SPx, rPx). Otherwise, the switching limits shift by the value of the set offset. 	
--	---

10.5 Setting of output signals

10.5.1 Setting of the output function for OUT1

<ul style="list-style-type: none"> ▶ Select [OU1] and set the switching function: <ul style="list-style-type: none"> [Hno] = hysteresis function/NO, [Hnc] = hysteresis function/NC, [Fno] = window function/NO, [Fnc] = window function/NC. <p>Note: If the upper switch point is used as an overflow protection, the setting OU1 = Hnc (NC function) is recommended. The principle of normally closed operation ensures that wire break or cable break is also detected.</p>	
--	---

10.5.2 Setting of switching limits (hysteresis function)

<ul style="list-style-type: none"> ▶ Make sure that the function [Hno] or [Hnc] is set for [OU1]. ▶ Select [SP1] and set the value at which the output switches. 	
<ul style="list-style-type: none"> ▶ Select [rP1] and set the value at which the output switches off. rP1 is always smaller than SP1. The unit only accepts values which are lower than the value for SP1. 	

10.5.3 Setting of switching limits (window function)

<ul style="list-style-type: none"> ▶ Make sure that the function [Fno] or [Fnc] is set for [OU1]. ▶ Select [FH1] and set the upper limit of the acceptable range. 	
---	---

<p>▶ Select [FL1] and set the lower limit of the acceptable range. FL1 is always lower than FH1. The unit only accepts values which are lower than FH1.</p>	
---	--

10.5.4 Setting of the switch-off delay

<p>▶ Select [dr1] and set the value between 0.2 and 5.0 s. At 0.0 (= factory setting) the delay time is not active. The switch-off delay is only active if hysteresis has been set as switching function (OU1 = Hno or Hnc).</p>	
--	---

10.5.5 Setting of the output function for OUT2 (analogue output)

<p>▶ Select [OU2]] and set the function: [I] = current signal 4...20 mA [U] = voltage signal 0...10 V</p>	
--	---

UK

10.5.6 Scaling of the analogue value

<p>▶ Select [ASP] and set the measured value at which 4 mA / 0 V is provided. ▶ Select [AEP] and set the measured value at which 20 mA / 10 V is provided.</p>	
--	--

10.5.7 Response of the outputs in case of a fault

<p>▶ Select [FOU1] / [FOU2] and set the value: [on] = the switching output switches ON in case of a fault; the analogue output goes to 20 mA / 10 V in case of a fault. [OFF] = the switching output switches off in case of a fault; the analogue output goes to 4 mA / 0 V in case of a fault. Factory setting: [FOU1] and [FOU2] = [OFF]. Faults: faulty hardware, too low a signal quality, untypical level curve. Overflow is not considered to be a fault.</p>	
--	---

10.5.8 Setting of the delay time after signal loss

<p>▶ Select [dFo] and set the value between 1 and 5 s. At 0 (= factory setting) the delay time is not active. Mind the dynamics of your application. In case of fast level changes it is recommended to adapt the value step by step.</p>	
---	---

10.6 Reset of all parameters to factory setting

- ▶ Select [rES], then press [Set] and keep it pressed until [----] is displayed.
- ▶ Press [Mode/Enter] briefly.
- > During the storage operation the display goes out for several seconds. Then the unit restarts and the factory settings are restored.

Note: On delivery the unit is not operational. First, the basic settings must be entered (→ 10.2).

rES

10.7 Changing basic settings

Required after a factory reset [rES] and after changes to the probe or to the application area.

10.7.1 New entering of the probe length

Approach for single probes:

- ▶ Measure the rod length L to a precision of ± 2 mm (± 0.1 inch). L = lower edge of the of process connection to the rod end.
- ▶ Round up the measured value (step increment 0.5 cm / 0.2 inch).
- ▶ Select [LEnG] and set the value (setting range: 10.0 ... 160.0 cm / (4.0 ... 63.0 inch)).

Approach for coaxial probes:

- ▶ Measure the total length L_K of the coaxial probe to a precision of ± 2 mm (± 0.1 inch).
- ▶ Deduct 9 mm from the measured value. $L = L_K - 9$ mm.
- ▶ Round up the determined value (step increment 0.5 cm / 0.2 inch).
- ▶ Select [LEnG] and set the value (setting range: 10.0 ... 160.0 cm / 4.0 ... 63.0 inch).

Note: After changing the probe length, the values for OFS and the switching limits must also be reviewed / re-entered.

LEnG

10.7.2 Setting to another medium

- ▶ Select [MEdI] and set the value:
 - [HIGH] for water and water-based media.
 - [LOW] for oils and oil-based media.

Note: In case of doubt, carry out an application test to ensure the setting which is best for your medium.

MEdI

10.7.3 New entering of the type of probe used

<ul style="list-style-type: none"> ▶ Select [Prob] and set the value: <ul style="list-style-type: none"> - [rod] for single probe. - [COAX] for coaxial probe. • The detection of water and water-based media is possible with the single probe as well as with the coaxial probe. • The detection of oils and oil-based media is only possible with the coaxial probe. Therefore, the parameter [Prob] is not available in case of the setting [MEdl] = [LOW] (the value [COAX] is preset). 	
--	---

11 Operation

UK

After power on, the unit is in the Run mode (= normal operating mode). It carries out its measurement and evaluation functions and generates output signals according to the set parameters.

11.1 Operating indicators

Numerical value + LED 1	Current level in cm.
Numerical value + LED 2	Current level in inch.
Numerical value + LED 3	Current level in % of the final value of the measuring range.
LED 8	Switching status of the corresponding output.
[----]	Level below the active zone.
[FULL] + numerical value alternately	Level has reached or exceeded the maximum measuring range (= overflow warning).
[CAL]	Initialisation phase after power on
====	On delivery the unit is not operational. Basic settings required (→ 10.2).
[Loc]	Unit electronically locked; parameter setting impossible. For unlocking press the two setting buttons for 10 s.
[uLoc]	Unit is unlocked / parameter setting is possible again.

11.2 Reading of the set parameters

- ▶ Press [Mode/Enter] briefly to scroll the parameters.
- ▶ Press [Set] briefly to indicate the corresponding parameter value for about 15 s. After another 15 s the unit returns to the Run mode.

11.3 Changing the display unit in the Run mode

(= switching between length indication (cm / inch) and percentage).

► Press [Set] briefly in the Run mode.

> The selected unit is displayed for 15 s, the corresponding LED is lit.

With each push of the button the display type is changed.

11.4 Error indications

	Possible cause	Recommended measures
[E.000] ... [E.030]	Fault in the electronics.	Replace the unit.
[E.031]	Probe detached from the unit; possibly incorrect setting of the probe length.	Check whether the probe is still attached to the unit. Check the parameter [LEnG].
[E.032]	Measurement considerably disturbed; possibly incorrect setting of the probe length.	Check the application (→ 11.5), check the parameter [LEnG].
[E.033]	No reflection signal.	Check the application (→ 11.5).
[E.034]	Plausibility problem caused by abrupt level change.*	Check the application (→ 11.5).
[SC1]	Flashing: short circuit in switching output 1.	Remove the short circuit.

* The unit carries out plausibility checks to increase the operational reliability.

11.5 Remarks on application-related malfunction

Possible cause	Recommended measures
Measurement disturbed by foam formation or strong turbulence.	<ul style="list-style-type: none"> • Install the unit in a still pipe or bypass. • Set or increment [dFo] (→ 10.5.8).
Measurement disturbed by separation layers e.g. oil layer on water.	Remove the oil layer by suction, stir the medium, verify the composition.
Rod or process connection soiled.	Clean the rod and the process connection, carry out a reset**.
Installation conditions were not adhered to.	Follow the instructions in chapter 6 Installation.
Block distance exceeded by more than 10 mm.	Lower the level; follow the instructions in chapter 6 Installation.
Atypical, abrupt level changes.*	Carry out a reset**.
Probe length, type of probe or sensitivity (setting to the medium) set incorrectly.	Correct the settings. Follow the instructions in chapter 10.2. Carry out a reset**.

* The unit carries out plausibility checks to increase the operational reliability. Atypical level changes can be caused e.g. by contact with the rod. They can also be caused by heavy soiling or turbulence. With the parameter dFo the response of the unit can be delayed (→ 10.5.8).

** Carry out a reset (power off and on again) after rectifying the fault and to reset the error message.

11.6 Output response in different operating states

	OUT1	OUT2
Initialisation	OFF	OFF
Normal operation	according to the level and OU1 setting	according to the level and OU2 setting
Fault (E.0xx)	OFF for FOU1 = OFF; ON for FOU1 = on	4 mA / 0 V for FOU2 = OFF 20 mA / 10 V for FOU2 = on

12 Scale drawing

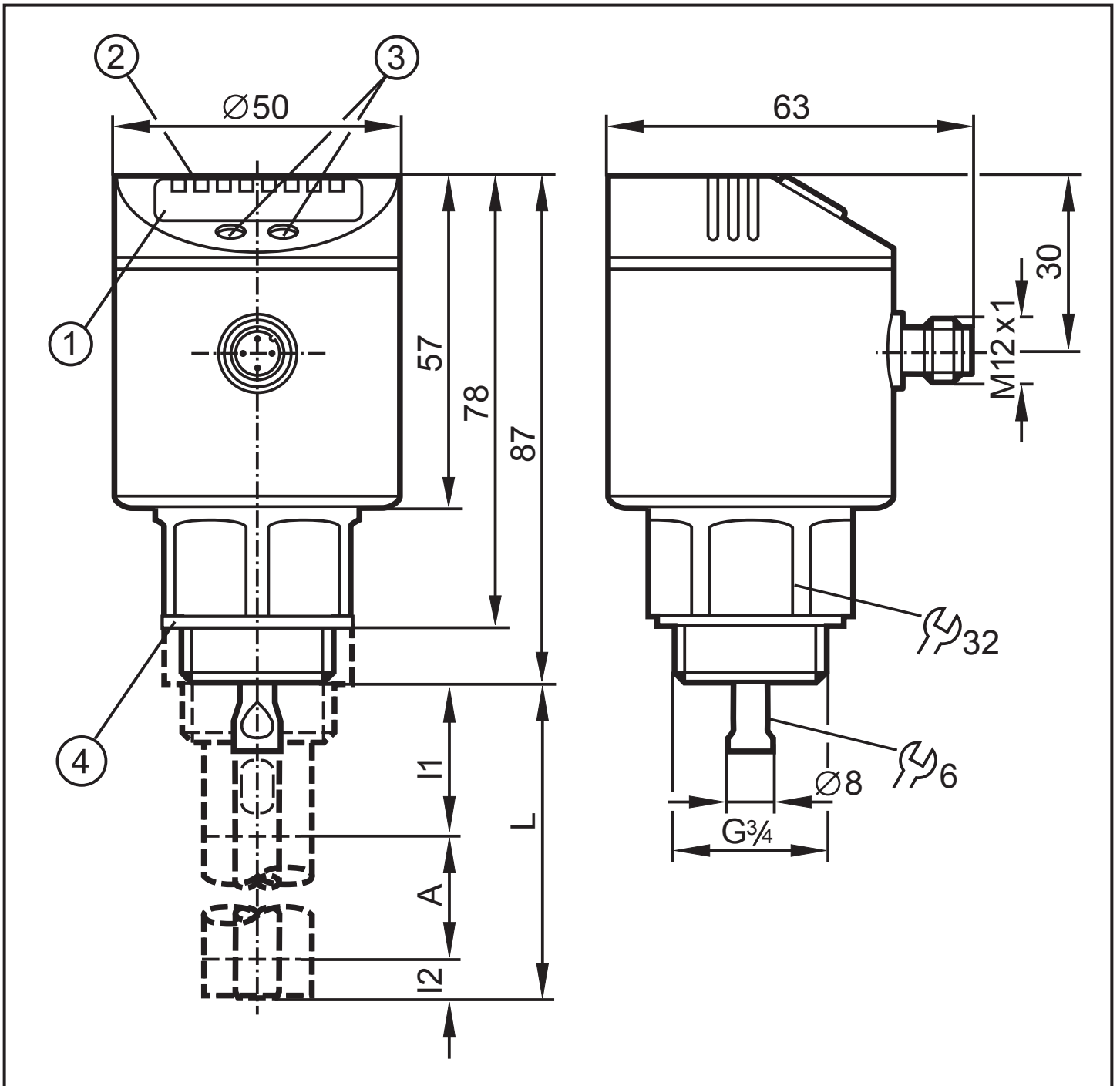

Dimensions in mm

1: display; 2: status LEDs; 3: programming buttons; 4: seal

	cm		inch	
	min	max	min	max
L (probe length)	10	160	4.0	63
A (active zone)	6 (4)	L - 4 (L - 6)	2.4 (1.6)	L - 1.6 (L - 2.4)
I1 (inactive zone 1)	3		1.2	
I2 (inactive zone 2)	1 (3)		0.4 (1.2)	

The values in brackets apply to the setting [MEdI] = [LOW] (setting for the detection of oils and oil-based media).

13 Technical data

Operating voltage [V].....	18 ... 30 DC
Current rating [mA].....	200
Short-circuit protection, pulsed; protected against reverse polarity and overload	
Voltage drop [V].....	< 2.5
Current consumption [mA].....	< 80
Analogue output	4 ... 20 mA (max. 500 Ω) / 0 ... 10 V (min. 2000 Ω)
Zero signal [mA / V]	3.6 ... 4.0 / 0.0 ... 0.2
Full signal [mA / V]	20.0 ... 20.8 / 10.0 ... 10.3
Resolution [mm]	0.5 ¹⁾ / 0.2% A ²⁾
Measuring sensitivity [mA/V per mm]	16 mA ÷ A [*]) / 10 V ÷ A [*])
Offset error [cm]	± 1.0
Characteristics deviation [cm]	± 1.0
Switch point accuracy [cm].....	± (1.5 + 0.5% A) [*]
Repeatability [cm] ± 0,5	
Max. speed of the level change [mm/s].....	100
Dielectric constant medium	> 2
Max. tank pressure [bar]	-1...4
Housing materials. stainless steel (304/1.4301); FKM; NBR; PBT; PC; PEI; TPE / V; PTFE	
Materials (wetted parts).....	stainless steel (303/1.4305); PTFE; NBR
seal.....	Tesnit
Protection	IP 67, III
Ambient temperature [°C].....	0...60
Medium temperature [°C]	
- permanently.....	0...80
- short-term	0...90
Storage temperature [°C].....	-25...80
Shock resistance [g].....	12 (DIN EN 60068-2-29, 11 ms)
Vibration resistance [g].....	2.5 (RMS, 1...1000 Hz)
EMC.....	IEC 60947-1

* A = active zone (→ 12 Scale drawing)

¹⁾ active zone (A) up to 250 mm

²⁾ active zone (A) 250..1550 mm

13.1 Setting ranges

[LEnG]	cm	inch
Setting range	10...160	4.0...63
Step increment	0.5	0.2

[OFS]	cm	inch
Setting range	0...100	0...39.4
Step increment	0.5	0.2

The setting ranges for the switching limits (SP1, rP1, FH1, FL1) depend on the probe length (L). In general the following applies:

	cm		inch	
	min	max	min	max
SP1 / FH1x	1.5 (3.5)	L - 3	0.6 (1.4)	L - 1.2
rP1 / FL1	1.0 (3.0)	L - 3.5	0.4 (1.2)	L - 1.4
Step increment	0.5		0.2	

The values apply if [OFS] = 0. The values in brackets apply to the setting [MEdI] = [LOW] (setting for the detection of oils and oil-based media).

- rP1 (FL1) is always smaller than SP1 (FH1). If the value for SP1 (FH1) is reduced to a value \leq rP1 (FL1), the position of rP1 (FL1) also shifts.
- If rP1 (FL1) and SP1 (FH1) are close together (approx. 3 x step increment), rP1 (FL1) is changed automatically when SP1 (FH1) is increased.
- If there is a greater distance between rP1 (FL1) and SP1 (FH1), rP1 (FL1) maintains the set value even if SP1 (FH1) is increased.

The setting ranges for the analogue start point (ASP) and the analogue end point (AEP) depend on the probe length (L). In general the following applies:

	cm		inch	
	min	max	min	max
ASP	1.0 (3.0)	---	0.4 (1.2)	---
AEP	---	L - 3.0	---	L - 1.2
Step increment	0.5		0.2	

Minimum distance between [ASP] and [AEP] = 25 % of the active zone..

The values apply if [OFS] = 0. The values in brackets apply to the setting [MEdI] = [LOW] (setting for the detection of oils and oil-based media).

14 Maintenance

- ▶ Keep the process connection free of deposits and foreign bodies.
- ▶ In case of heavy soiling: clean the process connection and the probe at regular intervals.

In case of longer operation separation layers can form in the medium (e.g. oil on water). This applies especially to still pipes or bypasses.

- ▶ Remove separation layers at regular intervals.
- ▶ Ensure that the vent hole (at the upper end of the coaxial pipe) remains free.
- ▶ Keep the interior of the coaxial pipe free from foreign bodies and soiling.

UK

15 Factory setting

	Factory setting	User setting
SP1 / FH1	100% SP/FHmax	
rP1 / FL1	100% rP/FLmax	
OU1	Hnc	
OU2	I	
OFS	0.0	
dr1	0.0	
FOU1	OFF	
FOU2	OFF	
dFo	0	
ASP	1.0 (3.0)*	
AEP	AEPmax	
Uni	cm	
SELd	L	
LEnG	nonE	
MEdl	nonE	
Prob	nonE	

SP/FHmax = LEnG value minus 3.

rP/FLmax = LEnG value minus 3.5.

When the LEnG value is entered, the program calculates the basic setting.

*The values in brackets apply to the setting [MEdl] = [LOW] (setting for the detection of oils and oil-based media).

More information at www.ifm.com